

KS3

Food and Nutrition



Name.....

Group.....

Teacher.....

Food Curriculum Assessment Log

		KS3	KS4
DIET	I can identify healthy eating advice		
	I can describe current healthy eating advice		
	I can explain current healthy eating advice and list the nutrients in food		
	I can apply the current healthy eating advice to my own needs and describe the functions of nutrients in food.		
	I can compare my diet to others with similar nutritional needs.		
	I can identify the problems associated with malnutrition and obesity		
	I can explain the differences between the nutritional needs of different groups of people.		
	I can create recipes that cater for the nutritional requirements of others.		
	I can develop recipes using nutritional analysis programmes to suit the nutritional needs of a variety of different groups.		
CONSUMER AWARENESS (Food Origins)	I can identify food is produced in different ways		
	I can describe the different influences on the availability of food e.g. seasonality		
	I can explain the difference between organic and non-organic food.		
	I can name the 6 R's of sustainability		
	I can describe the effect of the 6 R's on food production and sustainability.		
	I can explain the benefits of fair trade, organic farming and other moral, ethical issues.		
	I can evaluate the effects of social, moral and ethical factors affecting food and its availability		
	I can investigate information available to the consumer regarding food labelling, availability, traceability, animal welfare and assured food standards		
	I can analyse future food predictions, which will be influenced by geography, weather and climate.		
FOOD CHOICE	I can name factors that influence food choice, such a specialist diets		
	I can explain the benefits of supermarket own brands, using greengrocers, butchers instead of large supermarkets.		
	I can describe dietary influences on food choice.		
	I can discuss the influence of role models and food marketing on food choice.		
	I can develop a recipe for someone with a religious/ dietary requirement		
	I can compare the cost of making my own recipe to shop bought or eating out.		
	I can create low cost recipes/ products using left overs where appropriate.		
	I can analyse recipes/ products for their suitability for a variety of different dietary needs.		
	I can evaluate the role of lifestyle factors and advertising on food choice.		

FOOD LABELLING	I can list the information found on a food label.	KS3	KS4
	I can describe the information which is required by law.		
	I can evaluate this information and explain how it helps to inform the consumer.		
	I can discuss the difference between allergies and intolerance		
	I can interpret different food labels.		
	I can evaluate and compare different food labels.		
	I can analyse food labels to make an informed choice.		
	I can propose how food labelling is helpful to the consumer.		
	I can evaluate various methods of informing consumers via food labels.		

Cooking (Food preparation and handling skills)	I can name, collect and safely use simple equipment with some help and degree of accuracy.		
	I can identify a range of preparation techniques.		
	I can safely use most equipment with my level of accuracy increasing.		
	I can demonstrate a wide range of preparation techniques and processes.		
	I can work increasingly independently with a range of equipment to produce a quality finish to some of my products made.		
	I can work independently with a range of equipment and processes to produce a quality finish to most of my products made.		
	I can choose the right equipment and processes safely to produce a creative product with a quality finish.		
	I can select the right equipment and processes to creative and innovative product that has a professional finish.		
	I can choose from a wide range of equipment and processes independently with perfect accuracy, skills and precision to make a highly creative and professionally finished product.		

Food Safety	I can name basic food safety principles.		
	I can get myself ready to cook following these principles and be aware that food purchased and cooked needs to be stored in different conditions.		
	I can recognise that some foods have a greater risk of food poisoning and contamination than other.		
	I can recognise the importance of preparing and cooking food safely and hygienically.		
	I can implement the principles when preparing, cooking and storing food.		
	I can explain the principles of food safety and hygiene and implement them individually.		
	I can describe what are date marks and storage instructions on food and drink labels and why they are used.		
	I can plan and carry out food storage, preparation and cooking in a safe and hygienic manner.		
	I can explain the principles of cleaning, preventing cross		

	contamination, chilling, cooking and reheating food.		
Active Lifestyles	I can identify how an active lifestyle is good for health.	KS3	KS4
	I can explain why I need to drink more when active and what happens if I become dehydrated.		
	I can describe how much physical activity I should do in a day and what the benefits are.		
	I can identify the basics of how physical activity affects health.		
	I can identify why it is important to include a variety of activities in everyday living.		
	I can describe how different activities can affect health in different ways.		
	I can explain how physical activity contributes to physical, social and mental wellbeing.		
	I can explain the links between when and what to eat and drink before, during and after exercise.		
	I can understand how water is used by the body during physical activity and how extra water is needed, before, during and after physical activity.		

TEACHER GRADE		
---------------	--	--









Food Preparation and Nutrition Mark Scheme

Read the mark scheme below. Circle where you aim to be by the end of the rotation in each area. Be realistic in your target setting.

		Emerging	Developing	Securing	Mastering
Analysis	Research Effectiveness	Simple list of observations. e.g. The good and the bad points of a product.	Observations and opinions are supported by sensory words.	Depth of thought. Evidence how the research has informed the product outcome.	Well justified observations supported by sensory words. Clear evidence of how the research has informed the product outcome.
	Competence and Accuracy	Product presented in an appropriate manner although quality of finish/garnish needs improvement.	Product presented attractively using simple presentation techniques.	Product presented to a good standard.	Products produced with a variety of skills and presented to a high standard.
Making	Independence and Confidence	Complete a product with support (product would otherwise be incomplete). Clears up areas with prompts.	Use most techniques and processes to complete a product independently. Independently wash up and clear up area.	Use appropriate techniques and processes in a confident and organised manner. Clears area and shared spaces efficiently, independently and as part of a team.	Use appropriate techniques and processes to produce a product independently within the time available. Demonstration of awareness of health and safety at all times.
	Objective and Developmental	Simple list of good and bad points of a finished article.	Simple list, containing sensory words, of good and bad points of a finished article.	Some explanation of how the finished article could be improved if the make was repeated.	Explanation of how a finished article could be adapted and in what ways this would improve the product.
Technical	Knowledge and Understanding	Begin to apply technical knowledge in the test kitchen.	Demonstrate some understanding of the technical aspects in the test kitchen, including understanding of nutrition.	Use technical knowledge and understanding to explain how and why products are successful or not, including the nutritional value of food products.	Use of advanced technical understanding of ingredients, techniques and processes in the test kitchen.

MY PROGRESS









Unit: KS3 Hygiene and Safety

	Start   	During   	End   	Teacher assessment
	Self assessment	Self assessment	Self assessment	
Know I know basic H&S principles				
Understand I understand the reason for H&S and why they are important.				
Do I follow the H&S rules during practical lesson				

Catch up activity	
Now focus on..	

MY PROGRESS









Unit: KS3 Nutrition

	Start   	During   	End   	Teacher assessment
	Self assessment	Self assessment	Self assessment	
Know I know healthy eating advice.				
Understand I can describe the reasons for healthy eating and identify nutrients in various foods.				
Do I can describe the functions of nutrients in my food products.				

Catch up activity	
Now focus on...	

MY PROGRESS









Unit: KS3 Making

	Start   	During   	End   	Teacher assessment
	Self assessment	Self assessment	Self assessment	
Know I know the names of equipment and how to use them				
Understand I understand the stages of making to achieve a successful food product.				
Do I can complete a range of skills safely and independently.				

Catch up activity	
Now focus on...	

MY PROGRESS

Unit: KS3 Evaluation

	Start   	During   	End   	Teacher assessment
	Self assessment	Self assessment	Self assessment	
Know I can describe my food product using sensory vocabulary.				
Understand I know how to improve the nutritional content and change the flavour of my food product.				
Do I can complete all aspects of evaluation, including skills, food choices and own performance.				

Catch up activity	
Now focus on...	

Practical Self- and Teacher-Assessment

Place your initials in the appropriate box for each practical lesson and this will help you to check your progress. Your teacher will do the same and give you ongoing targets which you are responsible for to write down.

Practical				absent	Skills used/ targets	Teacher assessment
Pizza Toast						
Healthy Eating						
Fruit Crumble						
Fairy cakes						
Scones						
Scone based Pizza						
Macaroni Cheese						
Cheese and Onion Tartlets						
Pear marble tray Bake						
Food Safety						
Fajitas						
Vegetable Couscous Salad						
Paella						
Chicken Goujons with Coleslaw						
Maids of Honour						
Spaghetti Bolognese						
Bread						

Practical Skills used in your Food Preparation and Nutrition Unit

Skill	Techniques
General Practice skills	
Weigh and measure	Accurate measurement of liquid and solids
Select and adjust cooking times	Select and adjust the cooking process and length of time to suit the ingredient for e.g.: to match the cut of meat and alternatives
Test for readiness	skewer, visual colour check to establish whether an ingredient or recipe is ready
Judge and modify sensory properties	Change the taste and aroma through the use of herbs and spices. Presentation of food through garnishes and careful assembly.
Knife Skills	
Fruit and Vegetables	Bridge hold, claw grip, peel, slice, dice, and cutting to even sizes.
Meat or alternatives	Prepare raw and cooked meat or alternatives (such as tofu, halloumi or cheese).
Preparing fruit and vegetables	
Preparing fruit and vegetables	Grate, peel, wash and dry where appropriate)
Use of the cooker	
Using the grill	Use a range of foods such as vegetables, meat, or alternatives, such as halloumi to grill or toast.
Using the oven	Baking
Use of equipment	
Using equipment	Use of food processor, mixer, microwave oven.
Cooking methods	
Water based methods using the hob	Boiling and simmering
Dry heat and fat based methods using the hob	shallow frying, stir frying.
Prepare, combine and shape	
Prepare, combine and shape	Roll, wrap, mix, coat, layer ingredients, whilst demonstrating the technical skill or preventing cross contamination and handling high risk foods correctly.

Hygiene, Health and Safety Rules in the Food Preparation Area

Before you start the lesson

It is important that you understand the rules of the classroom before we begin. If you follow the instructions below then we shall all be safe and the chances of any accidents occurring are greatly reduced. If you are to participate in practical lessons you must follow the following rules:

- Line up quietly outside the room
- Do not enter the room without the teacher's permission
- Remove your coat and bags from shoulders before entering the room
- Store food items from home in the place chosen by your teacher
- Put coats and bags out of sight in a safe place

During the lesson

There is a difference between hygiene and safety, although in some situations hygiene issues can affect your safety. Make sure you follow these rules:

Hygiene	Safety
<ul style="list-style-type: none">• Wash your hands before beginning practical work• Tie back long hair• Do not wear nail varnish• Remove jewellery• Always wear an apron• Do not cough or sneeze on food• Do not lick your fingers• Make sure utensils and cutlery are washed and dried thoroughly• Clean all worktops at the end of the lesson	<ul style="list-style-type: none">• Do not run• Take care when using knives• Mop up spills immediately• Take care with electricity• Turn pan handles to the side• Use oven gloves to remove food from the oven• Be aware of the emergency exits and the procedure should there be a fire• Report any problems to your teacher• If you are not involved in practical work you should not sit near pupils who are preparing food

Safety Rules for a Safe Kitchen

There is a lot of dangerous equipment so it is very important that we act in a safe and careful way. Make a list of rules that you consider to be important in a food preparation area, give reasons for each rule and label the rules in order of importance:

Safety rules	Reason for the rules	Order of importance
Always wipe up spills immediately	So that no-one slips and hurts themselves	

At the end of the lesson

Just think about how you would like the room to be when you start your practical. Would you like your equipment to be dirty from the previous lesson? Would you like to work at a desk covered in bits of food? Probably not! In order to maintain the hygiene of the room it is important that you follow the rules below:

1. That your cooker has been turned off and wiped
2. Pack your food items away and make sure they are kept cool and covered
3. That the equipment is returned to the correct places
4. That your floor area has been swept and checked
5. That all worktops and tables have been thoroughly cleaned
6. That your sink has been checked and wiped down
7. That all cloths and towels used during the lesson have been placed in the linen basket
8. Ask your teacher to check your working area
9. Return your apron and collect your coat and bag ready to be dismissed

Knife Safety Assessment

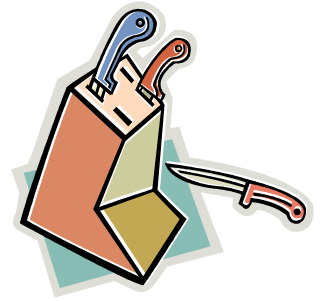

You need to pass your kitchen knife safety training in order to be allowed to use kitchen knives in Food Technology.

Answer the following questions **before** your knife safety assessment.

1. How should you carry knives in the Food Technology classroom?

.....

.....

.....

2. Explain how you would wash your knife when you have finished using it:

.....

.....

.....

You will be required to pass a practical assessment of your knife skills. To be successful you will need to demonstrate that you can use a knife safely and with confidence.

	Teachers Signature	Student Signature
Congratulations you have passed your knife safety assessment!		



Weighing and Measuring

For good results in most recipes, **accurate** weighing and measuring is essential. When you are baking with flour, sugar and liquids, making cakes you must measure accurately or your cooking will be spoiled. If you weigh out too much sugar or too little raising agent your cakes would not rise or you could spoil the taste.

Food can be weighed in **Grams (g)** and there are **1000g** in a **Kilogram (kg)**.

Electronic Scales



These are expensive to buy but simple to use. Simply measure the food into a bowl and watch the digits record the weight. These can weigh more accurately.



Spring Balance Scales

Before anything is weighed on these, make sure the pointer on the number face is at zero, when the scale pan is in place. Simply measure the food until the pointer reaches the weight you need.

Measuring Jug



A measuring jug is needed for measuring liquids. A jug which is marked in **millilitres (ml)** on one side and **pints** and **fluid ounces (fl oz)** on the other, showing both units is the most useful kind to have.

Liquids are measured in **millilitres (ml)** and **litres (l)**. There are **1000ml** in a **litre**.

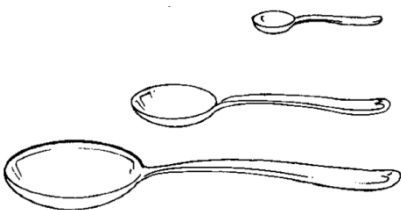

A teaspoon (tsp) holds 5ml
A dessert spoon (dsp) holds 10ml
A tablespoon (tbsp) holds 15ml



A selection of measuring spoons

Pizza Toast

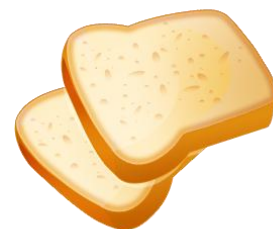

Ingredients:

2 Slices of Bread (or a bagel or a piece of French stick sliced in half)

2 x 5ml Spoons of Tomato Pizza Sauce

½ Pepper

1 Spring Onion

1 Mushroom

30g Hard Cheese, e.g. Cheddar or Edam

½ x 5ml Spoon Mixed Herbs

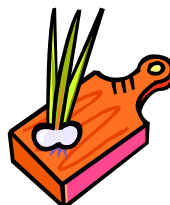

Please bring a container to carry your pizza toast home in.

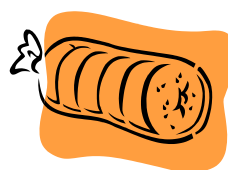

Equipment:

Weighing Scales, Chopping Board, Knife, Cheese Grater, Fish Slice, Measuring Spoons, Dessert Spoon, Grill.

Method:

1. Pre-heat the grill.
2. Slice the pepper, spring onions and mushroom.
3. Grate the cheese.
4. Place the bread under the grill and toast one side.
5. Remove the bread from the grill and place on the chopping board uncooked side up.
6. Spread the tomato sauce over the bread.
7. Arrange the pepper, mushroom and onion over the slices of bread.
8. Sprinkle the cheese and mixed herbs over the bread.
9. Place under the grill until the cheese bubbles.

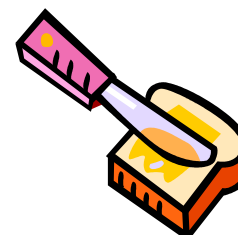

Top Tips:

- Why not add cooked sausage or chicken or canned tuna?
- Add a spoon of pickle or chutney for extra bite.

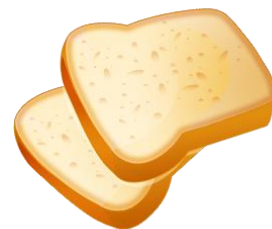

Pizza Toast Quiz

Starter: List the equipment you need to have ready before you begin cooking:

- 1.
- 2.
- 3.
- 4.
- 5.
- 6.
- 7.
- 8.

Questions:

1. Why must you use a chopping board when chopping vegetables?

.....



2. Give three safety points to remember when using the knife?

- a.
- b.
- c.

3. Give one safety point to remember when using the grill:

.....

4. Name two types of cheese you could use:

- a.
- b.

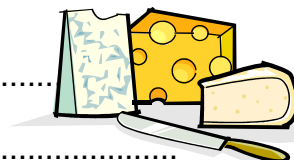

5. Which size holes of the grater should you use?

.....

6. What healthy food could you serve with your pizza toast?

.....



7. List two other toppings you could use on your pizza toast:

- a.
- b.

Plenary: List 2 useful points to remember when making pizza toast:

- a.
- b.

Sensory Word Bank

Appearance

- Attractive
- Bright
- Colourful
- Cracked
- Crispy
- Crumbly
- Crunchy
- Delicate
- Dry
- Dull
- Firm
- Flaky
- Fragile
- Fresh
- Heavy
- Moist
- Pale
- Smooth
- Soggy
- Spongy
- Stringy
- Wet

A product's size, shape, colour and surface texture can be described.

The nose detects volatile aromas released from food.

The intensity can also be recorded.

Aroma

- Artificial
- Bland
- Floral
- Fruity
- Minty
- Natural
- Nutty
- Plain
- Rich
- Salty
- Smokey
- Sour
- Spicy
- Sweet
- Stale
- Yeasty
- Zesty

Sensory Vocabulary

Sensory evaluation involves using one or more tests to determine different characteristics of food.

Foods can be evaluated for:

- Appearance
- Aroma
- Taste
- Texture

- Acidic
- Aftertaste
- Artificial
- Bitter
- Bland
- Creamy
- Dry
- Fruity
- Overpowering
- Plain
- Rich
- Savoury
- Sharp
- Sickly
- Stale
- Sweet
- Sugary
- Tangy
- Tasteless
- Zesty
- Yeasty

The tongue can detect four basic tastes: sweet, sour, salt and bitter. The intensity can also be recorded.

- Bitty
- Brittle
- Bubbly
- Chewy
- Crispy
- Dry
- Firm
- Flaky
- Fluffy
- Grainy
- Hard
- Lumpy
- Moist
- Rubbery
- Smooth
- Soft
- Soggy
- Spongy
- Stodgy
- Tough
- Wet

The EATWELL GUIDE

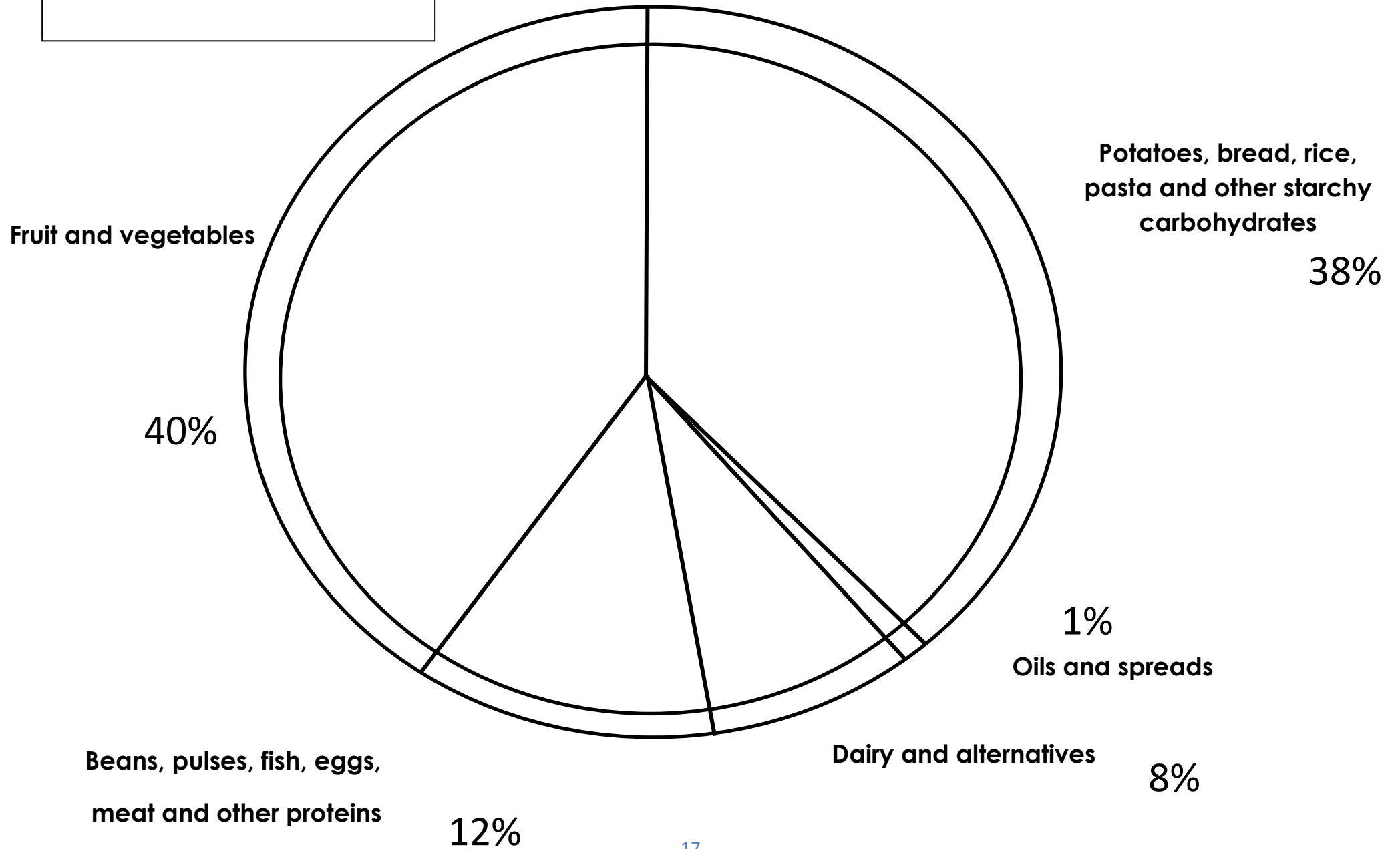

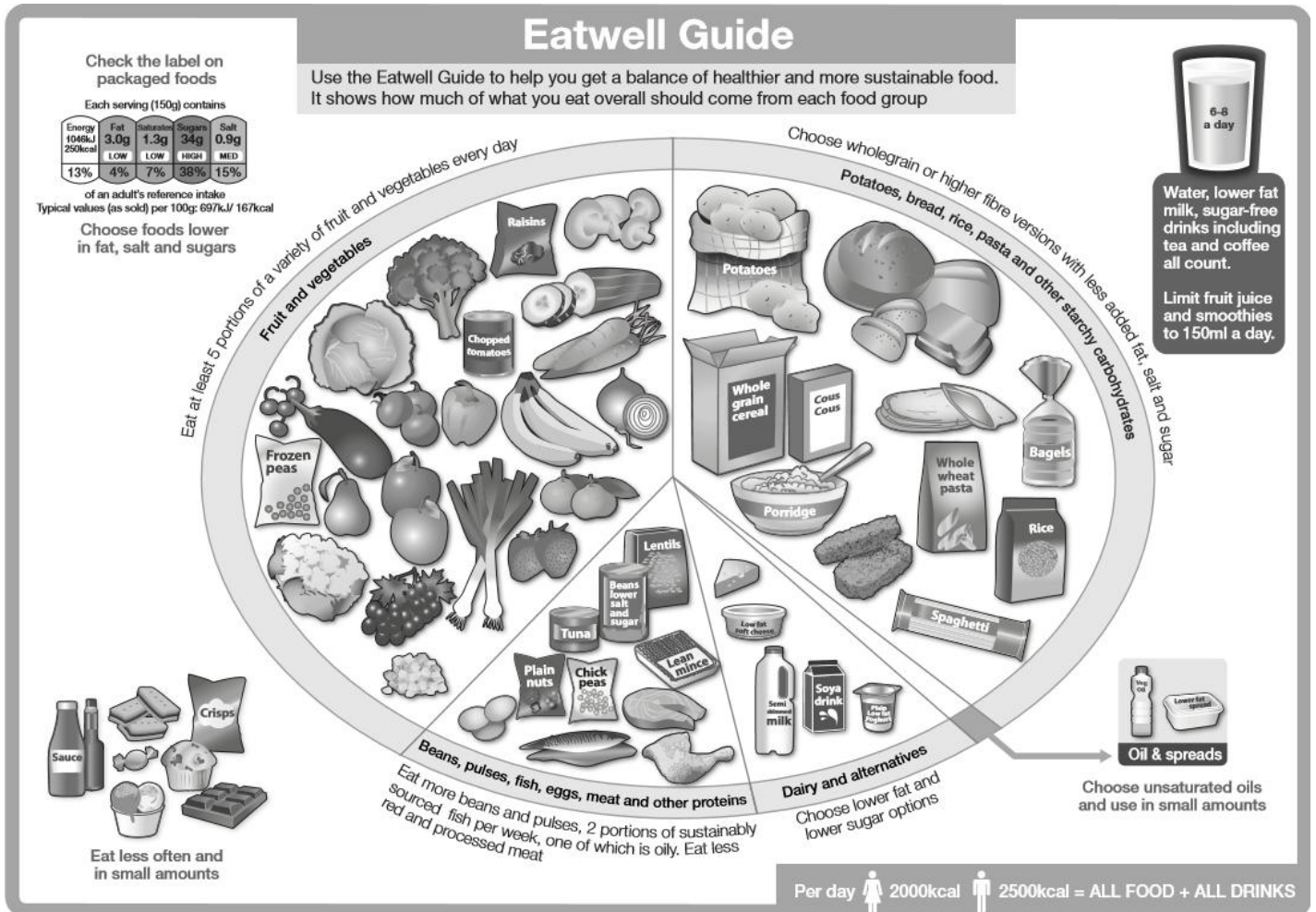

The UK government recommends to eat as outlined on the 'Eatwell guide'.

Where do you find important nutrients?

Nutrients	Food examples
Carbohydrates- starch	
Carbohydrates- sugar	
Protein	
Fat	
Water	
Fibre	

Macro
Nutrie
nts

Micro Nutrients

Nutrients	Food examples
Vitamin C	
Calcium	
Iron	

Protein Information

animal nuts repair pulses growth

Complete the word gap task:

Proteins assist with _____ and _____ of the body. Proteins are found in _____ products like meat, fish, cheese, milk and eggs. Vegetable sources include soya-bean products, _____ and _____.

Protein rich foods are classified into **High Biological Value (HBV)** and **Low Biological Value (LBV)**.

HBV protein rich foods, mainly from animal sources, contain large numbers of amino acids and can be absorbed by the body quickly

LBV rich foods, mainly from plant sources, contain less amino acids than HBV foods and need to be eaten with other (complementary) foods, so the body can absorb them.
(examples: Beans on toast, Macaroni cheese)

Complete the table using the list of foods below. Classify them as animal or non-animal proteins and whether they are HBV or LBV.

Animal	HBV or LBV	Non-animal	HBV or LBV
		Grains	LBV

- Nuts Poultry Tofu Meat
- Fish Dairy Eggs Soya
- Pulses ~~Grains~~ TVP (textured Vegetable Protein) Cereals

12



What is Quorn?
.....

What are the benefits of eating Quorn over meat?
.....

Carbohydrate Information

Complete the word gap task:

starch cereals sugar energy fruit

Carbohydrates are needed to give the body _____. There are two types of carbohydrate - _____ and _____. Starch is found in _____, cornflour, potatoes, pasta and flour. Sugar is found in _____, vegetables, honey, milk and malt products.

2a. When might the body need fast release (sugary) carbohydrates?

2b. When might the body need slow release (starchy) carbohydrates?

3. Complete the table using the list of foods below. Classify them as fast or slow release carbohydrate.

Fast (aka simple carbohydrate)	Slow (aka complex carbohydrate)

Fruit	Sugary Cereal	Potatoes	Peas
Jam	Oats	Energy Drinks	Rice
Vegetables	Honey	Lentils	Milk

Which type of foods contain gluten?

If you were gluten intolerant (coeliac) which foods could you get your carbohydrates from?

.....

.....

.....

.....

Fats Information

1. Complete the word gap task:

butter insulate saturated energy plant

Fats help to provide concentrated sources of _____ and help to _____ the body in cold weather. There are two main types: _____ fats are usually obtained from animal sources, for example _____ and lard. Unsaturated fats come from _____ sources, such as sunflower oil.

Complete the table using the list of foods below. Classify them as saturated or unsaturated fats.

Saturated Fats	Unsaturated Fats

Meat
Butter

Nuts
Vegetable Oil

Cream
Eggs

Olive Oil
Oily Fish



What health risks does this boy face? If you were his parent, how would you change his diet?

Response:

Health Risks:

.....

Changes to diet:

.....

.....

.....

.....

8 Tips for Eating Well

To grow and be healthy we need to eat a variety of foods. We should choose more of some and less of others:

1. Base your meals on starchy foods

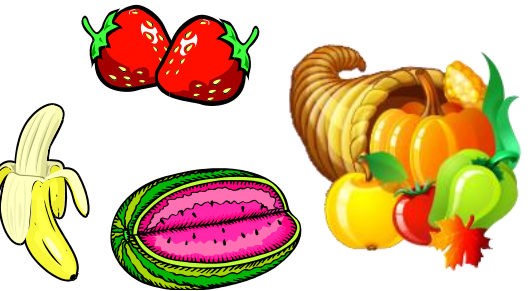

2. Eat lots of fruit and vegetables

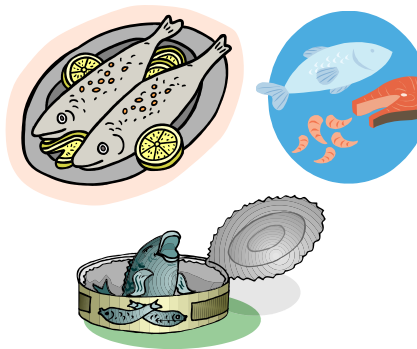

3. Eat more fish: Including 1 portion of oily fish / week



4. Cut down on saturated fat and sugar

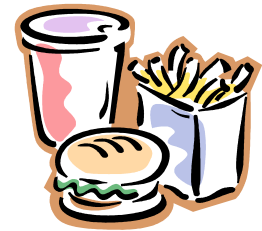

5. Try to eat less salt: no more than 6g a day for adults



6. Get active and try to be a healthy weight



7. Drink plenty of water

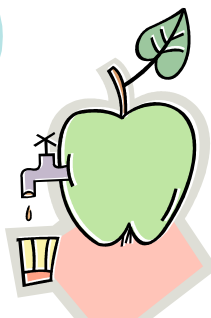
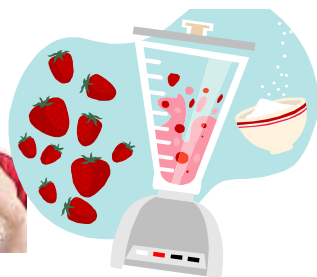

8. Don't skip breakfast

Which of these tips do you do well?.....

Which ones do you need to improve on?.....

Fruit Crumble

Ingredients for Fruit Base:

500g Fresh Fruit e.g. Cooking Apples, Plums, Rhubarb

50g Caster Sugar

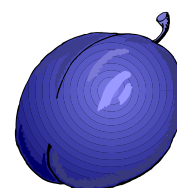

Please bring an ovenproof dish to cook and carry your fruit crumble home in.

Ingredients for Crumble Topping:

150g Plain Flour

75g Butter

50g Caster Sugar

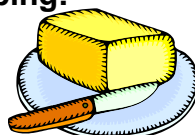

Equipment:

Weighing Scales, Chopping Board, Sieve, Knife, Mixing Bowl, Wooden Spoon, Peeler, Saucepan, Oven Proof Dish/Foil Tray, Baking Tray.

Method:

1. Pre-heat the oven to gas mark 5 of 180°C.
2. Sieve the flour into the mixing bowl.
3. Cut the butter into small pieces and rub it into the flour until it looks like breadcrumbs.
4. Stir in the sugar.
5. Prepare the fruit according to the type of fruit you decide to use, e.g. peel, core and thinly slice apples; wash and stone plums; wash and cut rhubarb.
6. If you are using rhubarb you should stew it in a saucepan with the sugar with 200ml of water. Simmer for 5 minutes with the lid on the pan to part soften the fruit before putting it into the oven.
7. Place fruit in an ovenproof dish. Sprinkle the sugar over the fruit.
8. Add the crumble topping and smooth it over the fruit.
9. Place the ovenproof dish or foil tray onto a baking tray and bake in the oven for 30-40 minutes until the crumble is golden brown.

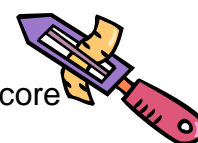

Fruit Crumble Quiz

Starter: List the equipment you need to have ready before you begin cooking:

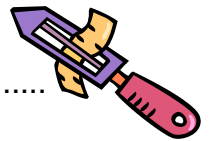

- | | |
|---------|---------|
| 1. | 5. |
| 2. | 6. |
| 3. | 7. |
| 4. | 8. |

Questions:

1. Should the margarine be hard or soft?.....

2. Give one way you could adapt the recipe to make it healthy:

.....



3. What must you remember when using the rubbing in method?

.....

4. Suggest two other fruits that could be used in a fruit crumble:

- a. b.

5. Why must you use an ovenproof dish?

.....

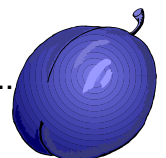

6. What safety points should you remember when using a vegetable peeler?

.....

7. Sort the ingredients into the food groups

Carbohydrate	Protein	Fat

Fruit Crumble Evaluation

...to be completed in full sentences

Comment on the aroma, appearance, taste and texture of your Food product

Aroma.....

Appearance.....

Taste.....

Texture.....

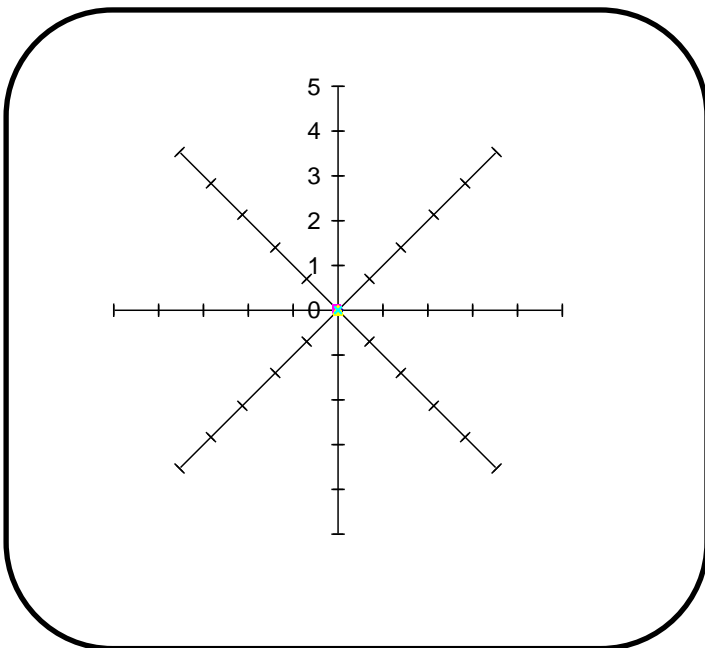

Use the word bank for further sensory descriptive words

Choose the most suitable for your star diagram

sweet, fruity, nutty, bland,

crunchy, firm, rich, zesty,

delicate, golden brown, brittle,

cracked, crumbly, sugary...

Which changes/adaptations could you make to improve your dish?

.....
.....
.....

How could you improve your own performance?

.....
.....
.....

Star Diagrams

A star diagram is used by the food industry to describe the appearance, aroma, taste and texture of food. It is often used to compare products and it is an easy way to compare several factors at once, for example, the sweetness and sponginess of a cake.

As the name suggests a star diagram is set out in the shape of a star. Each arm of the star is labelled with a **descriptor** – a word that describes the product. Each arm in the star is divided into five sections and the taster gives each word a score out of 5. The scale used is 5 = excellent and 1 = poor. The score is marked on the star diagram with a cross. The crosses are joined up to show the **product profile**.

From the star diagram a **product profile** is written which describes a food products appearance, aroma, taste and texture.

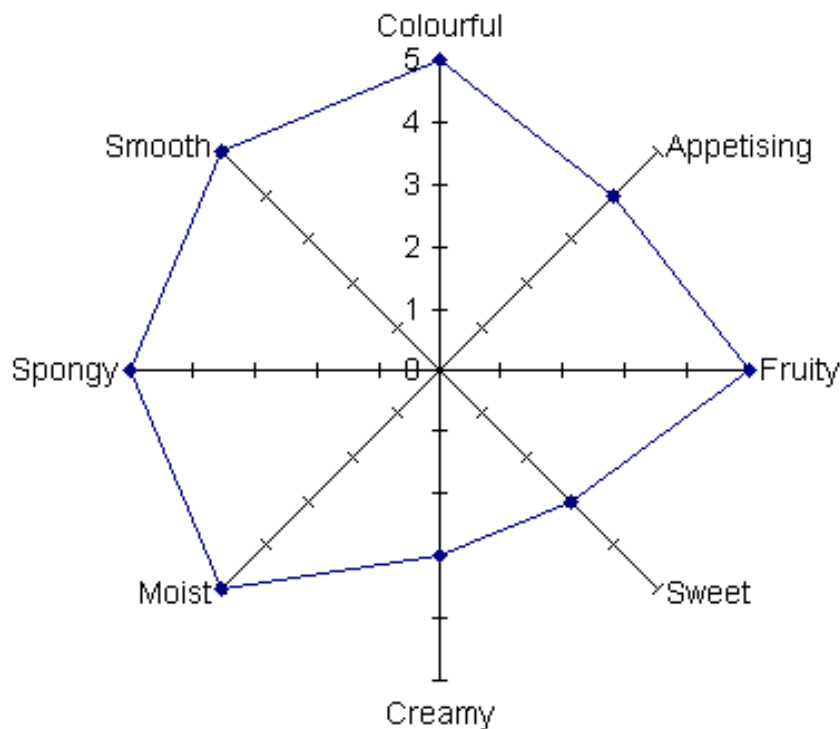

Fairy Cakes



Ingredients:

- 100g Self Raising Flour
- 100g Caster Sugar
- 100g Butter or Margarine
- 2 Eggs



For the icing

- 250g icing sugar
- 3 tbsp fresh lemon juice or water
- few drops food colouring, optional

Please bring paper cake cases and a container to carry your fairy cakes home in.

Optional Ingredients:

- 1/4tsp Lemon Rind
- 1/2tsp Orange Rind
- 1/4tsp Cinnamon
- 1/4tsp Vanilla Flavouring
- 50g Dried Mixed Fruit

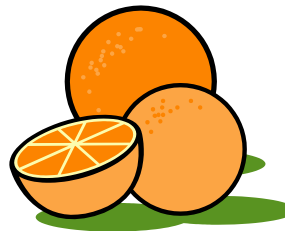

Equipment:

Weighing Scales, 12 Cake Cases, Cake Tin, Sieve, Mixing Bowl, Wooden Spoon, 2 Metal Spoons, Fork, Measuring Spoons, Electric Whisk and Cooling Rack.

Method:

1. Pre-heat the oven to Gas 5 or 190°C.
2. Place paper cake cases in cake tin.
3. Sift the self raising flour into a bowl.
4. Into the same bowl as the self raising flour, add the caster sugar, butter and eggs.
5. Add any additional ingredients.
6. Use the electric whisk to whisk the mixture until light and creamy. The mixture should have a good dropping consistency.
7. Divide the mixture carefully between the paper cases using the two metal spoons to help you.
8. Place in oven and bake for 15 minutes until well risen and golden brown.
9. Leave to cool. Decorate as desired.





Fairy Cakes Quiz

Starter: List the equipment you need to have ready before you begin cooking:

- | | |
|---------|----------|
| 1. | 6. |
| 2. | 7. |
| 3. | 8. |
| 4. | 9. |
| 5. | 10. |

Questions:

1. Why is it important to pre-heat the oven?

.....

2. What ingredient do whisk together?

.....



3. Should you use plain flour or self raising flour when making cakes?

.....



4. What type of spoon should you use to put the mixture into the paper cake cases and why?

.....

5. Why is it very important you do not open the oven until your cakes are fully cooked?

.....

6. Why should you put the cakes on a cooling rack to cool?

.....

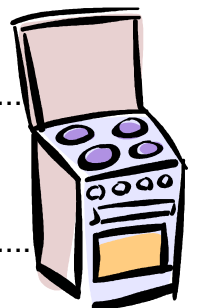

Plenary: Suggest 2 ways you could adapt your cake to make it more interesting:

a.

b.

Fairy Cake Evaluation



Drawing of your finished Fairy Cakes:

Label your cakes for ingredients, shape and colour.

Describe who your fairy cakes would appeal to and why:

Describe how your fairy cakes smell:

Summarise the taste of your fairy cakes:

Ask a friend to taste your fairy cakes and summarise what they thought:

Discuss what you found easy when making your fairy cakes:

What could you do better if you were to make your fairy cakes again:

Give yourself a mark out of ten for your overall work and finished fairy cakes:

Sweet Scones- egg free - makes 8

Ingredients:

250g white self-raising flour
50g margarine
75g caster sugar
50g dried fruit, glace cherries or coconut-
optional
125 ml milk
Milk to glaze



Equipment:

Weighing scales, measuring jug, bowl, sieve, rolling pin, oven tray, shape cutter

Method:

1.

Preheat the oven to gas mark 7 or 210°C. Place a baking tray into the oven to heat. No need to grease.

2.

Sieve the flour into a bowl, add small pieces of margarine.

3.

Rub the fat into the flour seconds until the mixture looks like bread crumbs

4.

Add the sugar and fruit.

5.

Gradually add the milk, make sure it's not too wet. Collect the dough into a ball.

6.

Tip the dough onto a floured surface and using one hand, knead the mixture to form a soft dough. Lightly dust a rolling pin with flour and roll the mixture to 2 ½ cm. Cut out using a 6cm cutter.

7.

Glaze the tops with milk. Remove the heated tray from oven and arrange scones on it. Bake for 10-15 min until golden brown. Remove from baking tray immediately with a knife.

Scones Quiz



Starter: List the ingredients and quantities you need to make your scones:

- 1.
- 2.
- 3.
- 4.

Questions:

1. Why is it important to sieve the flour?



.....

2. You need to rub in the butter or margarine into the flour until it resembles what?

.....

3. Why is it important to add the milk a little at a time?



.....

4. How thick should you roll out the dough to?

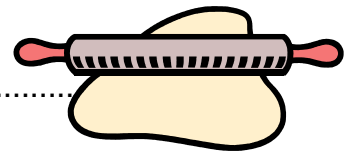

.....

5. Why is it important you do not twist the cutter when cutting the dough?

.....

6. Suggest two other ingredients could you use to glaze the scones?

- a.
- b.



Plenary: Design a label for the front of a scone packet:

Science Investigation- Raising Agents in Scones

AIM: Making a batch of scones, and investigating the most effective raising agent in terms of external and internal appearance, texture, degree of rise and flavour.

Equipment:

You will need for each variation:

Digital scales, Mixing bowl, Sieve, Small knife, Flour dredger, Rolling pin, Scone cutter, ruler or Scone rolling guides, Palette knife, Measuring jug, Pastry brush, Baking tray, Oven gloves, Cooling rack, Digital timer / stopwatch / clock with a second hand, Serrated knife

Ingredients:

Control – 115g plain flour, pinch of salt, 5g baking powder, 15g butter, 70ml fresh milk.

Repeat the above experiment with the following variations:

Variation 1 – 115g self-raising flour, pinch of salt, 15g butter, 70ml fresh milk.

Variation 2 – 115g plain flour, pinch of salt, 15g butter, 2.5g bicarbonate of soda, 5g cream of tartar, 70ml fresh milk.

Variation 3 – 115g plain flour, pinch of salt, 15g butter, 5g bicarbonate of soda, 70ml fresh milk.

Method:

1. Preheat oven to 230°C (210°C if using a fan oven)
2. Sift the flour, salt and raising agent/s into the mixing bowl.
3. Cut the butter into small pieces, then use your fingertips to rub it into the flour until the mix resembles fine breadcrumbs.
4. Add the milk all at once and mix quickly to form a soft dough.
5. Knead gently for a few seconds until the dough becomes smooth, and then roll out onto a lightly floured surface to a 2cm height.
6. Cut into rounds using a scone cutter, making sure that you use the same size cutter for each variation and that each scone is rolled out to the same thickness.
7. Glaze the tops, not the sides, with milk.
8. Bake at 230°C (210°C if using a fan oven) for 10 minutes.
9. Remove from oven and transfer to a cooling rack. Make sure that the scones are clearly labelled so that they do not become muddled up.
10. Use a serrated knife to cut one scone from the Control and each Variation in half, so that you have 2 half-moon shapes.
11. Measure the height of each one with a ruler. Examine the texture and appearance (including the colour), and then taste the scones

Results Compare your findings in the table below:

Comments	Control	Variation 1	Variation 2	Variation 3
External appearance				
Internal appearance/ texture				
Degree of rise				
Flavour				

1) Conclusions Summarise your findings here. You should consider the following:

Rank samples in order of preferred rise

Rank samples in order of preferred appearance.....

Rank samples in order of preferred texture.....

Rank samples in order of preferred flavour.....

2) In your opinion, which is the most successful sample? Explain your answer.

.....

3) Write a paragraph explaining the action of the raising agents when scones are baked.

.....

.....

.....

.....

.....

Extension: What happens to your scones if too much raising agent is added?

.....

Extension: What happens to your scones if too little raising agent is added?

.....

Please bring a pizza box to carry the pizza home in.

Scone Based Mini Pizza

Ingredients

- 150 g self raising flour
- 25 g margarine
- 1 egg
- 50 ml semi skimmed milk

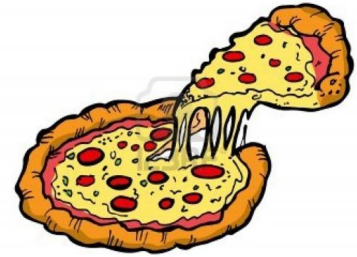

Topping:

- 3 x 15 ml spoons of passata sauce or tomato puree
- 50 g cheese

Optional:

- 2 mushrooms
- 1 tomato
- ½ green pepper
- 25 g sweet corn
- 1x5ml spoon of dried herbs



Equipment

Baking tray, weighing scales, sieve, mixing bowls, measuring jug, small bowl, fork, palette knife, flour dredger, spoon, chopping board, knife, measuring spoons, grater

Method:

1. Preheat the oven to 200°C or gas mark 6
2. Grease a baking tray
3. Sift the flour into a bowl
4. Rub the butter or margarine into flour until it resembles bread crumbs
5. Whisk the egg and milk together in a small bowl with a fork
6. Add the egg mixture to the flour and mix together to form a soft dough.
7. Flatten out the dough on a floured surface and form mini circles
8. Transfer the small circles of dough to the baking tray.
9. Spread the passata sauce over the dough using the back of a spoon
 - Prepare the vegetables: slice the mushrooms
 - Slice the tomato,
 - Remove the core from the green pepper and slice into thin strips
10. Arrange the mushrooms, tomato slices, green pepper and sweet corn over the base
11. Grate or slice the cheese
12. Sprinkle or place the cheese and herbs over the top of the pizza
13. Place the pizza in the oven and bake for 10-15 minutes, until golden brown

Top tips:

- Experiment with different toppings, such as slices of ham, tuna, red pepper, onion, or different types of cheese.
- Add herbs, spices, garlic or black pepper to the scone base mixture

Skills: using the oven, rubbing in, forming a dough/shaping, rolling out, mixing/combining, weighing, measuring, spreading

Scone Based Pizza Quiz

Starter: List the main ingredients to make the pizza base:

1.
2.
3.



Questions:

1. Why do you need to grease the baking tray?

.....

2. Which two ingredients do you rub in?

.....

3. What should the mixture look like when the fat has been rubbed in?

.....

4. Should the liquid be added 'all at once' or a 'little bit at a time'?

.....

5. Give two tips you need to remember when rolling out:

- a.
- b.

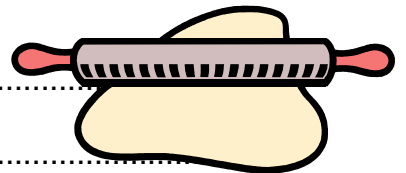

6. Suggest two toppings you could use for your pizza?

- a.
- b.

7. How can you tell if your pizza is cooked?

.....

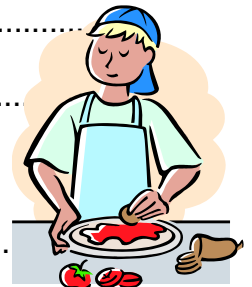

Plenary: Suggest 3 ways of reducing fat when making your pizza:

- a.
- b.
- c.

Score Based Pizza Evaluation

...to be completed in full sentences

Comment on the aroma, appearance, taste and texture of your Food product



Aroma.....

Appearance.....

Taste.....

Texture.....

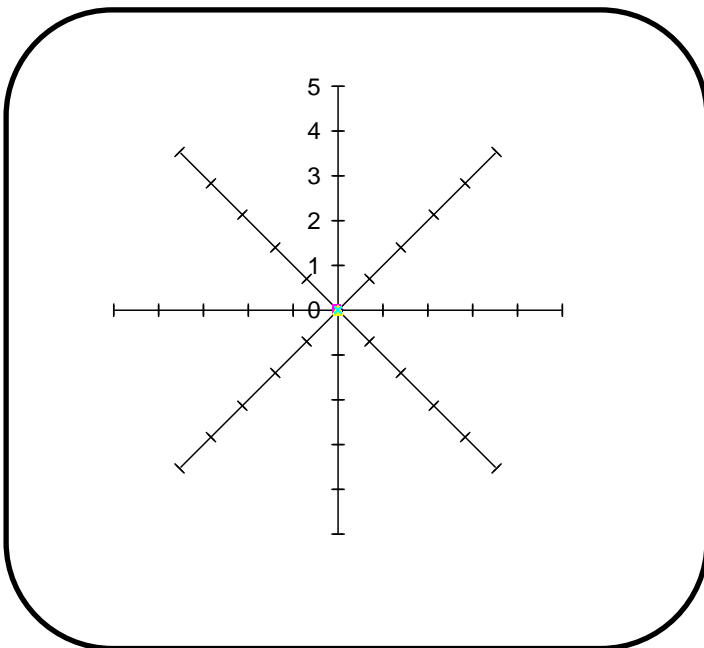

Use the word bank for further sensory descriptive words

Choose the most suitable for your star diagram

Savoury, colourful, soft,
crunchy, firm, rich,
delicate, golden brown, brittle,
cracked...

Which changes/adaptations could you make to improve your dish?

.....

.....

.....

How could you improve your own performance? Comment on the skills used.

.....

.....

.....

Important: Bring an ovenproof dish to cook and take your macaroni cheese home in.

Macaroni Cheese

Ingredients:

- 100g Macaroni
- 100g Cheddar Cheese
- 1 Tomato
- 25g Soft Margarine
- 25g Plain Flour
- 250ml Semi-Skimmed Milk
- Black Pepper



Equipment:

Two Saucepans, Weighing Scales, Grater, Chopping Board, Knife, Colander, Measuring Jug, Wooden Spoon, Whisk, Ovenproof Dish or Foil Tray.



Method:

1. Preheat the oven to 190°C or gas mark 5.
2. Bring a saucepan of water to the boil, and then add the macaroni. Cook for about 10-12 minutes, until al dente.
3. Grate the cheese and slice the tomato.
4. While the pasta is cooking, make the sauce.
 - ◆ Place the butter or margarine, flour and milk into a small saucepan.
 - ◆ Bring the sauce to a simmer, whisking it all the time until it has thickened.
 - ◆ Remove from the heat and stir in 75g of the grated cheese.
5. Drain the boiling hot water away from the macaroni into a colander in the sink.
6. Stir the drained macaroni into the cheese sauce and add a few twists of black pepper.
7. Pour the macaroni into an oven-proof dish or foil tray.
8. Arrange the tomato slices over the macaroni.
9. Sprinkle over the remaining cheese.
10. Bake in the oven for 15 to 20 minutes until golden.



Top Tips:

- ◆ Try different varieties of pasta shapes, such as rigatoni or shells.
- ◆ Add fresh herbs to the sauce, like chopped parsley or basil.
- ◆ During the last 2-3 minutes of cooking the macaroni, add a range of small pieces of vegetables, such as broccoli, cauliflower, courgette or peppers.



Macaroni Cheese Quiz

Starter: List 8 pieces of equipment you need to make your macaroni cheese:

1.
2.
3.
4.
5.
6.
7.
8.



Questions:

1. Why is it important to put the macaroni on to boil first?

.....

2. What are the 3 main ingredients of a white sauce?

- a.
- b.
- c.

3. Why is it important to continually whisk the white sauce?

.....

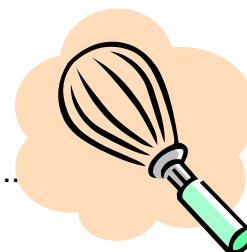

4. What is the piece of equipment called that you use to drain the pasta?

.....

5. What ingredient in the white sauce is responsible for the sauce thickening?

.....



Plenary: Suggest 2 other types of pasta you could use in your macaroni cheese:

- a.
- b.

1)The situation:

Health concerns: Prepared boxed and tinned macaroni and cheese is high in [saturated fat](#), [trans fat](#), [cholesterol](#), and [sodium](#) and low in [dietary fiber](#) and other essential nutrients (Wikipedia)

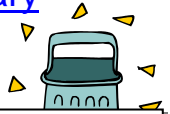

2) Design Brief:

Discuss and investigate the situation and adapt the recipe to create a healthier version of 'Macaroni Cheese'.

3) Analysis of our Macaroni Cheese recipe

Ingredients	Nutrition (Protein/carbohydrate/fat/fruit and vegetables/dairy)	Health benefits
100g Macaroni		
100g Cheddar Cheese		
1 Tomato		
25g Soft Margarine		
25g Plain Flour		
250ml Semi- Skimmed Milk		
Black Pepper		

How could you reduce the fat and salt content?

How could you introduce more fibre?

How could you introduce other flavours?

What are 'trans fats'?

Considering the ‘Eatwell Guide’ and the ‘8 Tips for eating well’:

1) What are the **good points** of Macaroni Cheese?

.....

.....

2) What can you **change or add** to this dish to make it healthier?

.....

.....

Use the table below to help you plan your macaroni cheese recipe:

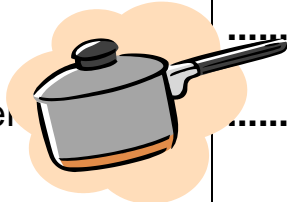
<p>Basic Ingredients:</p> <p>Ingredients:</p> <p>100g Macaroni</p> <p>100g Cheddar Cheese</p> <p>1 Tomato</p> <p>Black Pepper</p>  <p>The white sauce:</p> <p>25g Soft Margarine</p> <p>25g Plain Flour</p> <p>250ml</p> <p>Semi-Skimmed Milk</p>	<p>Your recipe:</p> <p>.....</p> <p>.....</p> <p>.....</p> <p>.....</p> <p>.....</p> <p>.....</p> <p>.....</p> <p>.....</p>
<p>Added flavourings and ingredients:</p>	
<p>Reasons for Choice:</p>	

Cheese and Onion Tartlets

Ingredients:

150g plain flour
70g margarine
6 teaspoons water (approx)

Filling:

1 large onion
1 large egg
100g grated cheese
Pinch pepper



Important: bring a container to take your tartlets home

Equipment:

Weighing scales, sieve, mixing bowl, measuring spoons, palette knife, flour dredger, rolling pin, bun tin, fork, chopping board, knife, grater, measuring jug.

Method:

1. Preheat the oven to 200°C or gas mark 6.
2. Make up the short crust pastry:
 - ◆ Sift the flour into the bowl.
 - ◆ Rub the butter or margarine into the flour, using your fingertips, until it resembles breadcrumbs.
 - ◆ Make a 'well' in the middle and add the cold water.
 - ◆ Mix to a dough with a round bladed knife.
3. Roll out the pastry, on a lightly floured surface.
4. Using a cutter a little larger than the bun tin, cut out the pastry bases.
5. Line the bun tin with the pastry
6. Finely chop the onion. Beat the egg and mix with the cheese, onion and pepper.
7. Carefully fill each of the pastry cases
8. Place in the centre of the shelf and bake for 20 minutes until golden brown.

Cheese and Onion Tartlets Quiz

Starter: List 8 pieces of equipment you need to have ready before you begin:

- | | |
|---------|---------|
| 1. | 5. |
| 2. | 6. |
| 3. | 7. |
| 4. | 8. |

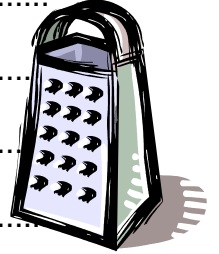

Questions:

1. Which 2 ingredients do you rub in?

.....

2. What should the mixture resemble when the fat has been rubbed in?

.....

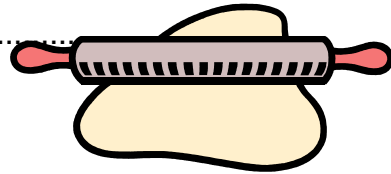

3. Give 2 tips you need to remember when rolling out:

.....

.....

4. Suggest 3 other ingredients you could add to your tartlets:

.....

5. Suggest 3 varieties of cheese you could use in your tartlets:

- a.

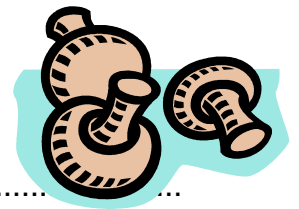

6. Sort the ingredients into the food groups

Carbohydrate	Protein	Fat

Function of Ingredients in Pastry

Flour:

Plain flour should be used for making pastry. For Short crust pastry, **soft** plain flour should be used to give a light crumbly texture.

For flaky and rough puff pastry, strong plain flour is best, as it has a higher protein content, resulting in the formation of more gluten when water is added. This enables the dough to stretch well and to produce flakes during preparation and baking.

Wholemeal flour can be used for short crust pastry to provide extra dietary fibre, vitamins, colour and flavour, but it is not suitable for flaky or rough puff pastry as it does not form flakes well, due to the presence of the bran.

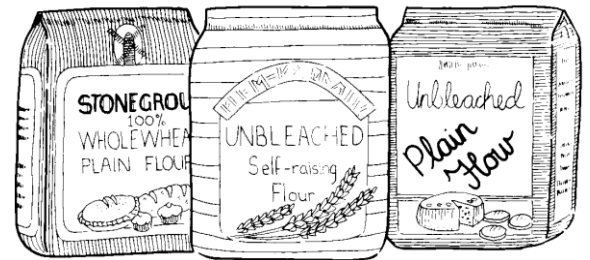

Fat:

Fat is used in pastry making to provide 'shortness' as in cake mixtures, except that for pastry, the fat is not mixed as thoroughly with the flour as it is for cakes. This causes the fat to form layers between strands of gluten, so that the pastry is tender and flaky.

Margarine is suitable for pastry making as it gives flavour, colour and some shortness. Block margarine is best to use as it is easier to rub in; soft margarine tends to be too oily.

Butter is suitable as it gives good flavour and shortness, but it is more expensive than margarine.

Lard is suitable as it provides very good shortness, but lacks flavour.

Oil can be used but also lacks flavour.



Liquid:

Water is used to bind the ingredients together into a dough. The water should be cold or chilled in the refrigerator so that it does not affect the temperature of the fats. Accurate measurement is important so that the correct consistency is produced. The water should be mixed in quickly with a flexible knife until a smooth dough is produced.

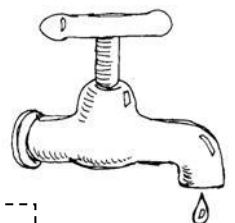

Tips:

- Make sure your hands, ingredients and utensils are cold.
- Handle pastry lightly and as little as possible to avoid heating the fat.
- Do not knead heavily or bash when rolling out.
- If you are not using the pastry straight away, put it in the fridge to rest.
- Always weigh the ingredients carefully

Function of Ingredients in Pastry

Flour

1) Name three different flours

.....

2) Which flour should be used in 'short' crust pastry.

.....

3) Which flour should be used in 'flaky' or rough puff pastry.

.....

4) What is the difference between strong and plain flour

.....

5) What does wholemeal flour provide?

.....

6) What is present in wholemeal flour to make it unsuitable for puff and or flaky pastry?

.....

Fat

Explain what 'shorten' the flour means

.....

Liquid

Explain the function of liquid in pastry

.....

.....

Marble Pear Tray Bake

Ingredients:

- 100g Caster Sugar
- 100g Soft Margarine
- 2 Eggs
- 100g Self Raising Flour
- 1 Tablespoon Coca Powder
- 1 Teaspoon Baking Powder
- ½ Pear

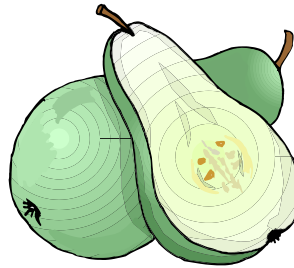

Equipment:

Baking Tin (20cm Square) or Foil Tray, Weighing Scales, Mixing Bowl, Electric Hand Whisk, Small Bowl, Fork, Sieve, Spoon, Chopping Board, Knife.

Method:

1. Preheat oven to 180°C or gas mark 4.
2. Grease and line the baking tin or foil tray.
3. Cream the sugar and margarine together, ideally using an electric hand whisk, until light and fluffy.
4. In a small bowl, beat the eggs with a fork.
5. Add the beaten egg, a little at a time, to the margarine and sugar and mix in with the electric hand whisk.
6. Sieve the flour and baking powder into a bowl.
7. Fold the flour and baking powder into the mixture, a spoonful at a time.
8. Core and chop the pear into small pieces. Scatter pieces of pear into the lined cake tin.
9. Spoon half of the plain cake mixture into the tin.
10. Stir-in the cocoa to the remaining cake mixture.
11. Spoon the chocolate mixture into the baking tin and then swirl the two mixtures together to create a marble effect.
12. Place in the oven and bake for 20 minutes until golden brown and springy to touch.
13. Remove from the oven and allow to cool.



Marble Pear Tray Quiz

Starter: List the 7 main ingredients you need to make your marble pear tray:

- 1.
- 2.
- 3.
- 4.
- 5.
- 6.
- 7.

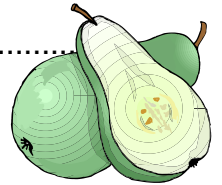

Questions:

1. Why is it important to grease and line the baking tray?

.....

2. Which two ingredients should you cream together?

.....

3. Suggest two advantages of using an electric whisk over a hand whisk:

- a.
- b.



4. What is the function of baking powder?

.....

5. Name 2 fruits you could use as an alternative to pears?

- a.
- b.

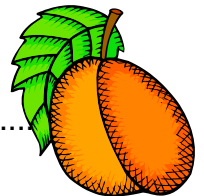

Plenary: Give 1 physical raising agent and 1 chemical raising agent for your marble pear tray:

- a.
- b.

Marble Pear Tray Evaluation

...to be completed in full sentences

Comment on the aroma, appearance, taste and texture of your Food product

Aroma.....

Appearance.....

Taste.....

Texture.....

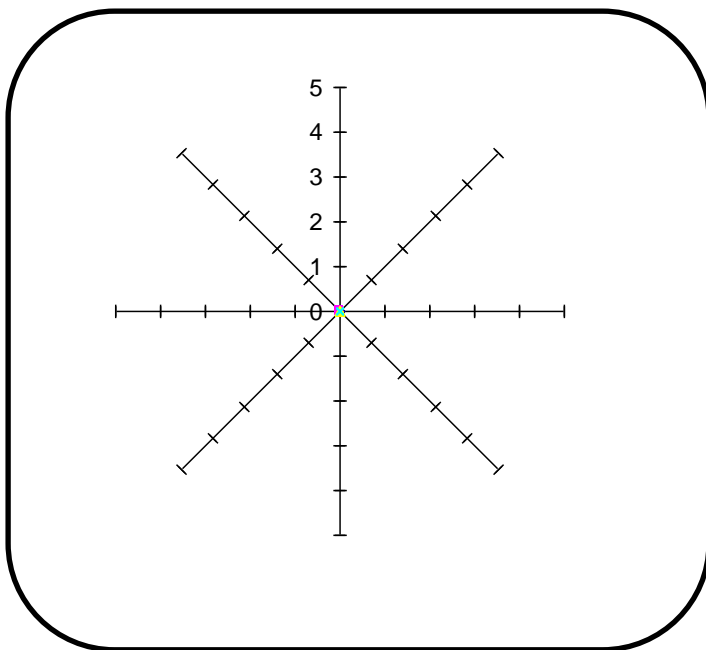

Use the word bank for further sensory descriptive words

Choose the most suitable for your star diagram

sweet, fruity, nutty, bland,

crunchy, firm, rich, zesty,

delicate, golden brown, brittle,

cracked, crumbly, sugary...

Which changes/adaptations could you make to improve your dish?

.....

.....

.....

How could you improve your own performance?

.....

.....

.....

The 4C's for Good Food Hygiene



Learning Objective

By the end of this activity you should know the 4C's for good food hygiene.

Keywords: hygiene, food poisoning, cross-contamination, temperature, try using the word **bacteria** rather than germs.

Food hygiene is about preventing food poisoning. Food poisoning bacteria can grow very quickly in food if it is not handled properly, cooked properly or stored properly. There are laws which control how food manufacturers can prepare and sell food. Statistics show that you are more likely to get food poisoning from a home-made meal than you are from a bought one. What are the symptoms of food poisoning?

Make a list of the types of food that are most likely to give you food poisoning. These are called 'high risk foods.'

Video

Watch the video from the Food Standards Agency and read brochure titled *Preventing Food Poisoning*. Write food hygiene rules of each of the 4C's. (<http://www.flyonthewall.com/FlyBroadcast/FSA/BacteriaBiteBusiness/>)

The 4C's

1. **C** _____

2. **C** _____

3. **C** _____

4. **C** _____

Marinating Meat:

The main reasons for marinating meat are:

.....

.....

.....

Ingredients used for marinating:

.....

.....

.....

The function of lemon or lime juice in marinating is

.....

.....

Fajitas

Ingredients:

- 1 Lime
- 1 Clove of Garlic
- 1 Green Chilli
- Small Bunch of Coriander
- 1 Dessert Spoon (10ml) Oil
- 1 Small Chicken Breast (or 3-4 Thighs)
- 1 small Onion
- 1 Pepper , any colour
- 1 Tomato
- 25g Cheddar Cheese
- 2 Tortillas
- 1 Tablespoon of Guacamole or Salsa (optional)

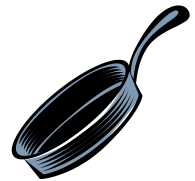

Equipment:

Weighing Scales, Juice Squeezer, Garlic Press, 2 Chopping Boards, 2 Knives, Small Bowl, 2 Spoons, Grater, Measuring Spoons, Frying Pan.

Method:

1. Prepare the marinade:
 - ◆ Squeeze the lime
 - ◆ Peel and crush the garlic
 - ◆ De-seed and slice the chilli
 - ◆ Chop the coriander
 - ◆ Stir everything together with the oil
2. Remove any skin from the chicken and cut the chicken into strips. Mix with the marinade and place in the fridge, covered, until needed.
3. Prepare the remaining ingredients with a clean knife on a clean chopping board:
 - ◆ Slice the onion and green pepper
 - ◆ Chop the tomato
 - ◆ Grate the cheese.
4. Add the marinated chicken to the wok or frying pan and stir-fry for about 4 minutes. Check that the chicken is cooked.
5. Add the onion and green pepper and continue to cook for a further 2 minutes.
6. Spread a little chicken in the centre of the tortilla, add some tomato, cheese and guacamole/salsa and then roll up.



Top Tips:

- ◆ Warm the tortillas in a microwave oven for 20 seconds.
- ◆ Go for extra vegetables or kidney beans for a vegetarian alternative.
- ◆ Other types of meat could be used, e.g. thin strips of beef or turkey.

Fajitas Quiz

Starter: List the 5 ingredients and their functions you need to make the marinade:

- 1.
- 2.
- 3.
- 4.
- 5.



Questions:

1. Why is important to remove any skin from the chicken?

.....
.....

2. Why is it important to use a clean knife and clean chopping board when preparing the vegetables?

.....



3. How can you check that the chicken is cooked?

.....

4. How long do you need to heat the tortillas in the microwave for?

.....

5. What is guacamole made from?

.....

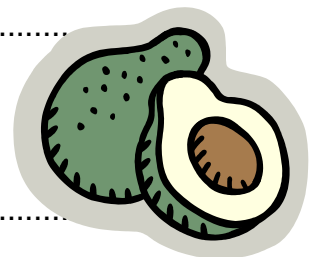

Plenary: Suggest 3 other meats you could use in your fajitas instead of chicken:

- a.
- b.
- c.



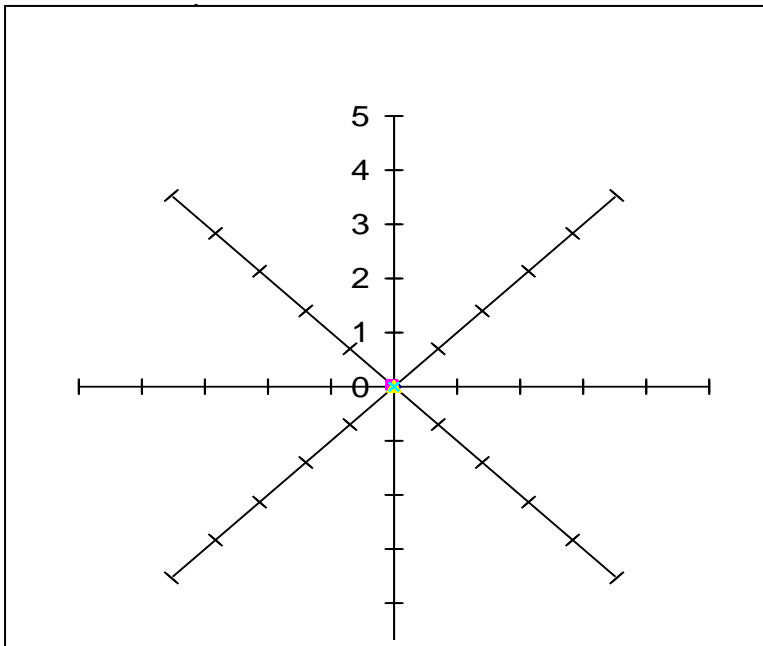

Fajitas Evaluation



Describe which skills you found easy when making your fajitas:

Describe which skills you found difficult when making your fajitas:

Tick the appropriate box on the hedonic scale for your product:

Hedonic scale	Like a lot 	Like a little 	Neutral 	Dislike a little 	Dislike a lot 
Me					
Friend					

Which changes/adaptations could you make to improve your dish?

.....

.....

.....

How could you improve your own performance? Comment on the skills used.

.....

.....

.....

Vegetable Couscous Salad

Ingredients:

- 175ml Water, Boiling
- 1 Vegetable Stock Cube
- 100g Couscous
- 1 Medium Tomato
- 1 Spring Onion
- ¼ Cucumber
- ½ Yellow Pepper
- 4 Dried Apricots
- 1 Small Bunch Parsley
- 2x15ml Spoons of Low Fat Dressing

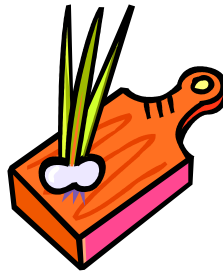

Please bring a container to carry your vegetable couscous salad home in.

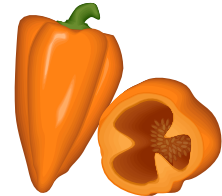

Equipment:

Kettle, Measuring Jug, Measuring Spoons, Weighing Scales, Large Bowl, Fork, Chopping Board, Knife, Scissors, Spoon, Container.

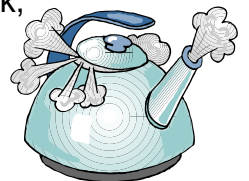

Method:

1. Make up the stock by dissolving the stock cube in the boiling water.
2. Pour the stock over the couscous in a large bowl.
3. Stir with a fork and leave to stand for 5 minutes.
4. Chop the tomato and cucumber into small chunks.
5. Slice the pepper into small strips.
6. Slice the dried apricots and parsley into small pieces.
7. Fluff the couscous with a fork and then add all the vegetables and snip the spring onions into the bowl using the scissors.
8. Stir everything together.
9. Add the dressing.



Top Tips:

- Vary the vegetables in the couscous dish, e.g. use celery, sweetcorn, peas, olives or mushrooms.

Vegetable Couscous Salad Quiz

Starter: List the equipment you need to have ready before you begin cooking:



1.
2.
3.
4.
5.
6.
7.
8.
9.
10.



Questions:

6. How do you make the stock?

.....

7. What do you need to do to all the vegetables before you start preparing them?

.....

8. Why do you need to 'fluff' the couscous with a fork?

.....



9. Suggest 3 alternative ingredients you could add to your couscous:

- a.
- b.
- c.

Plenary: Identify which parts of the 'Eatwell Guide' your vegetable couscous salad would fall under:

.....



Evaluation.....

...to be completed in full sentences

Comment on the aroma, appearance, taste and texture of your Food product

Aroma.....

Appearance.....

Taste.....

Texture.....

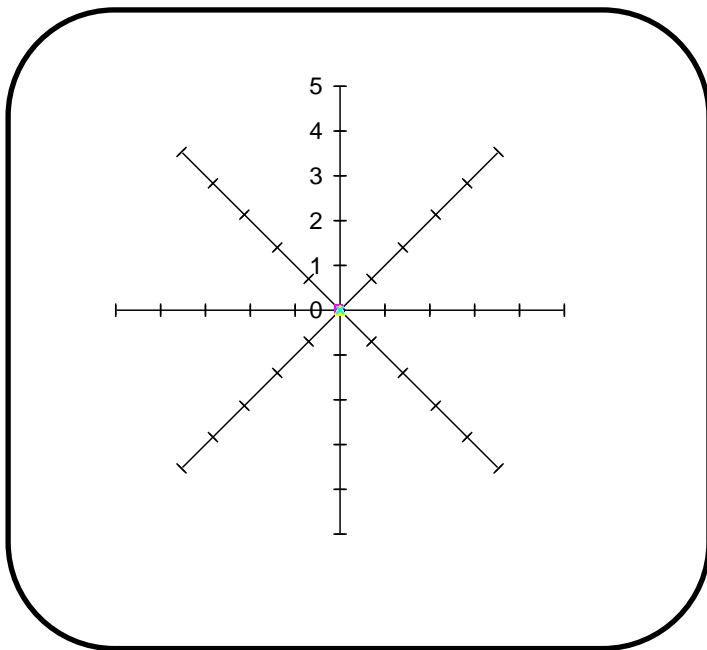

- 1) Use the word bank for sensory descriptive words to complete the star diagram.
- 2) List the skills you have used below:

.....

.....

.....

.....

Which changes/adaptations could you make to improve your dish?

.....

.....

.....

How could you improve your own performance?

.....

.....

.....

Paella

Ingredients	Functions of ingredients
1 small onion	
$\frac{1}{2}$ red pepper	
1 small chicken breast	
1 glove of garlic	
15 ml olive oil	
60g paella rice (long grain rice will work too)	
$\frac{1}{2}$ tsp turmeric, supplied	
Pinch of dried herbs	
25g peas	
25g chorizo sausage	
1 chicken stock cube	
200ml water	
Salt and pepper	

Equipment

Chopping board, vegetable knife, garlic press, weighing scales, frying pan, wooden spoon, kettle, measuring jug.

Method

1. Prepare the vegetables:
 - ◆ peel and chop the onion;
 - ◆ cut pepper in half and remove core and seeds and dice;
 - ◆ peel and crush the garlic.
2. Dice the chicken. Heat the oil and stir fry the chicken until lightly browned.
3. Add the onion, pepper and garlic in the oil and fry on a low heat until softened.
4. Add the rice and turmeric and cook for a minute. Remove from heat.
5. Mix the stock cube with boiling water, pour over rice and return to heat.
6. Bring to boil and then simmer until all the stock has been absorbed, stirring this will take 20 minutes. The rice should be soft, but still retain a nutty bite.
8. Add the herbs, peas and diced chorizo to the rice and cook for a few minutes to heat through. Garnish with parsley and a wedge of lemon.

Top tips

- ◆ Try using different ingredients, such as ham, mussels, squid or Mediterranean vegetables.

Skills

Using the hob	Bridge-hold	Claw-grip	Onion preparation	Frying Boiling Simmering
---------------	-------------	-----------	-------------------	-----------------------------

The 'Eatwell Guide'

The 'Eatwell Guide' is the UK governments recommendation how to eat for a healthy life style.



How does the Paella fit the 'Eatwell Plate'?

Which of the ingredients are:

Carbohydrates.....

Fruit.....

Vegetables.....

Fat.....

Protein.....



1) Which other ingredients could you add to the dish? Name the group they belong in.

.....

.....

Nutritional analysis

paella

Nutrition	Per 100g	Per 355g portion	RI (women)	RI (men)	RI (5-10 yrs)	
Energy	678 kJ	2404 kJ	29%	23%	32%	
Energy	162 kcal	574 kcal	29%	23%	32%	
Protein*	8.7 g	31 g	68%	56%	128%	
Carbohydrate*	15 g	54 g	24%	18%	25%	
Fat	6.7 g	24 g	34%	25%	34%	 orange

Traffic Light

- Green - a healthy choice
- Amber - OK most of the time
- Red - eat in smaller amounts

RI = 'recommended intake' of nutrients

The nutritional analysis shows that **one portion** of Paella provides:

.....Kcal energy

.....g protein

.....g carbohydrates

.....g fat

How much of the **RI for a woman** does the Paella provide?

.....% energy

.....% protein

.....% carbohydrates

per day is shown as a percentage.

Looking at the 'Eatwell plate', explain why the Paella is a reasonably healthy meal.

.....

.....

.....

Chicken Goujons with Healthy Coleslaw

Ingredients

For the Goujons

- 2 slices **white bread**, crusts removed
- 85g/3oz boneless **chicken breast**, cut into strips
- 2 tbsp plain flour
- 1 free-range **egg**, beaten
- 2 tbsp **olive oil**



Equipment:

Food processor, frying pan, fish slice, baking tray, fork, table spoon, medium size bowl for the egg plate for the flour, kitchen paper

Preparation method

1. For the goujons, place the bread slices into a food processor and pulse to crumbs, then scatter onto a baking tray.
2. Dust the chicken strips in the flour, then dip into the beaten egg and roll in the breadcrumbs. Repeat by dipping the strips into the egg again, followed by the breadcrumbs to make two layers.
3. Heat the olive oil in a frying pan and fry the goujons, in batches, for 2-3 minutes on both sides, or until golden-brown and cooked through. Drain on kitchen paper.

Ingredients

For the coleslaw

- 6 tbsp plain yogurt
- ½ tsp Dijon mustard
- 2 tbsp mayonnaise
- ½ white cabbage
- 2 carrots
- ½ onion

Equipment:

Grater, vegetable peeler, bowl, metal spoon.



Preparation method

1. Mix the yogurt, mustard and mayonnaise together in a bowl. Then, use a grater attachment on a food processor, or a box grater, to grate the cabbage and carrots. Either grate the onion or chop as finely as you can. Tip all of the vegetables into the bowl and stir through the dressing.
2. Will keep in the fridge for up to 3 days.

Nutritional analysis

chicken goujons with coleslaw

Revert to the or
Nutrition Progr

Nutrition	Per 100g	Per 602g portion	RI (women)	RI (men)	RI (5-10 yrs)	
Energy	529 kJ	3187 kJ	38%	31%	42%	
Energy	127 kcal	763 kcal	38%	31%	42%	
Protein*	6.4 g	38 g	85%	70%	160%	
Carbohydrate*	11 g	69 g	30%	23%	31%	
Fat	5.8 g	35 g	50%	37%	50%	

orange

Traffic Light

Green - a healthy choice

Amber - OK most of the time

Red - eat in smaller amounts

RI = 'recommended intake' of nutrients

The nutritional analysis shows that **one portion** of the dish provides:

.....Kcal energy

.....g protein

.....g carbohydrates

.....g fat

How much of the **RI for a woman** does the dish provide?

.....% energy

.....% protein

.....% carbohydrates

per day is shown as a percentage.

Looking at the 'Eatwell plate', explain why 'Chicken Goujons with healthy Coleslaw' is a reasonably healthy

.....

.....

.....



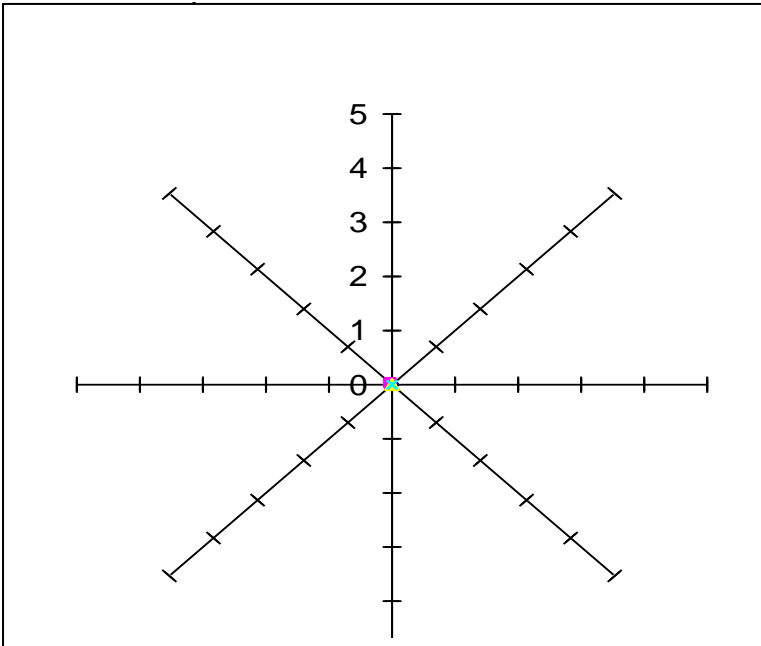

Evaluation



Describe which skills you found easy when making your product:

Describe which skills you found difficult when making your product:

Tick the appropriate box on the hedonic scale for your product:

Hedonic scale	Like a lot	Like a little	Neutral	Dislike a little	Dislike a lot
					
Me					
Friend					

Which changes/adaptations could you make to improve your dish?

.....

How could you improve your own performance? Comment on the skills used.

.....

Maids of Honour

Ingredients

- 150g plain flour
- 75g margarine
- 6tsp cold water (approx) to mix

For the filling:

- Jam
- 50g margarine
- 50g caster sugar
- 50g self-raising flour
- 1 egg.

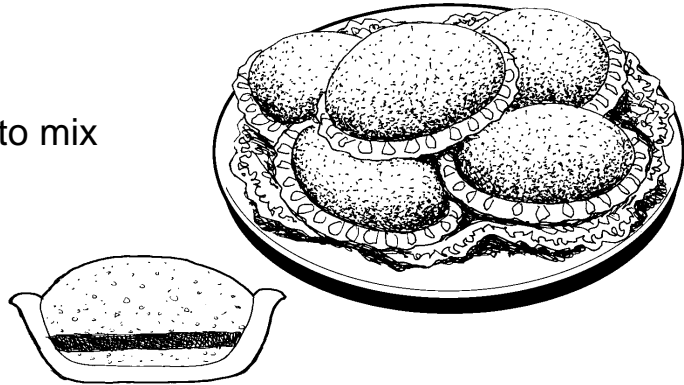

Equipment:

12 hole baking tray, Mixing bowl, Plastic/wooden spoon, Teaspoon, Round-bladed knife, Rolling pin, Tablespoon (metal), Electric whisk, Cooling tray, Palette knife, Measuring jug.

Method:

1. Weigh and measure out ingredients.
2. Preheat oven 200°C/Gas 6.
3. Prepare pastry: put flour into a mixing bowl and rub in fat until it resembles fine breadcrumbs.
4. Add cold water, a little at a time, mixing with a round-bladed knife until it becomes a stiff paste.
5. Put on a floured surface and roll out pastry thinly.
6. Using a pastry cutter, cut out rounds and line a 12 hole bun tray
7. Place half a teaspoon of jam in each.
8. For cake mixture: in mixing bowl cream margarine and sugar until light and fluffy, using a wooden spoon or an electric whisk.
9. Beat egg in measuring jug with fork.
10. Fold in beaten egg and flour to cake mix, using metal spoon.
11. Place a teaspoon of cake mixture in each pastry case.
12. Bake in oven for 15–20 minutes until cake is soft and springy to the touch.
13. Very carefully, using a palette knife, remove from bun tray and place on cooling tray.

Evaluation.....date.....
...to be completed in full sentences

Comment on the aroma, appearance, taste and texture of your Food product

Aroma.....

Appearance.....

Taste.....

Texture.....

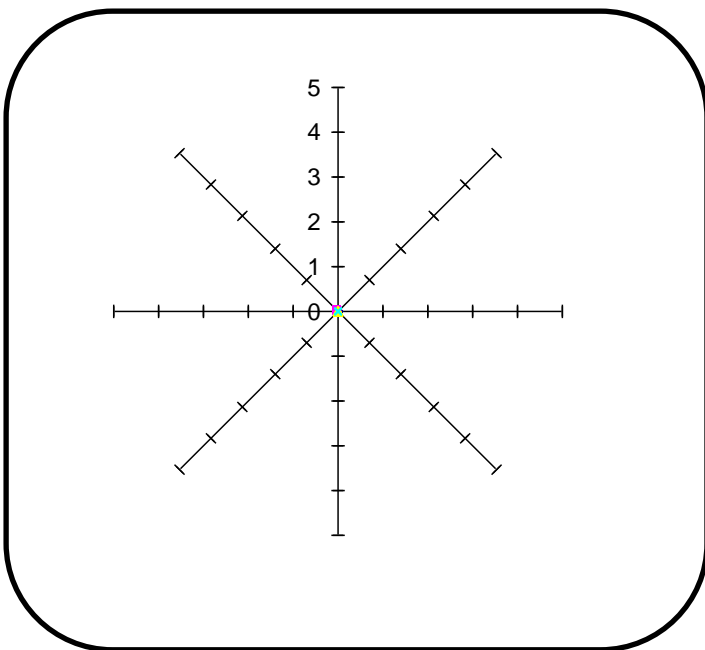

- 3) Use the word bank for sensory descriptive words to complete the star diagram.
 - 4) List the skills you have used below:
-
-
-
-

Which changes/adaptations could you make to improve your dish?

.....

.....

.....

How could you improve your own performance?

.....

.....

.....

Spaghetti Bolognese

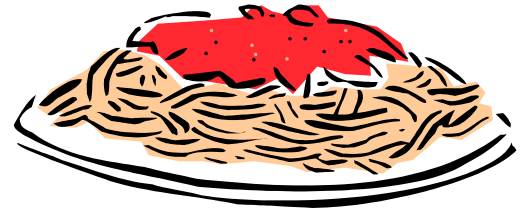

Ingredients for Sponge:

- 1 Onion
- 1 Clove of Garlic
- 1 Carrot
- 1 Celery Stick
- 1 Tablespoon of Oil
- 250g Minced Beef, Lamb or Turkey
- 400g Canned Chopped Tomatoes
- 1 Tablespoon Tomato Puree
- 100ml Water
- 1 Teaspoon Mixed Herbs
- Black Pepper
- 150g Spaghetti

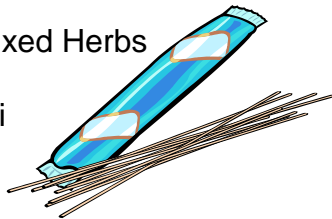

Equipment:

Weighing Scales, Chopping Board, Knife, Garlic Crusher, Peeler, Measuring Spoons, 2 Saucepans, Wooden Spoon, Colander.

Method:

1. Prepare the vegetables:
 - ◆ Peel and chop the onion
 - ◆ Peel and crush the garlic
 - ◆ Peel and slice the carrot
 - ◆ Finely slice the celery
2. Fry the onion, garlic, carrot and celery in the oil.
3. Add the meat and cook until the mince is lightly browned.
4. Add the tomatoes, tomato puree, mixed herbs and water and mix all the ingredients together. Then add a few twists of black pepper.
5. Bring to the boil, then simmer for 20 minutes.
6. Meanwhile place the spaghetti in a separate saucepan of boiling water. Cook for 10 - 12 minutes or until the spaghetti is al dente (tender).
7. Drain the boiling water away from the spaghetti into a colander in the sink.
8. To serve pour some of the bolognese sauce over the spaghetti.

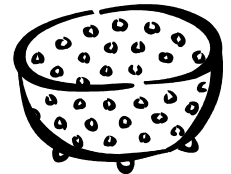

Top Tips:

- ◆ Try serving your spaghetti bolognese with parmesan cheese and fresh basil.
- ◆ For a vegetarian option swap the minced beef for veggie mince or lentils.

Spaghetti Bolognese Quiz

Starter: List 6 ingredients and their functions to make your Spaghetti Bolognese:

- 1.
- 2.
- 3.
- 4.
- 5.
- 6.



Questions:

1. What is the piece of equipment called that you use to crush garlic?

.....
.....

2. How do you know when the mince beef is cooked?

.....

3. How long do you need to cook spaghetti for?

.....

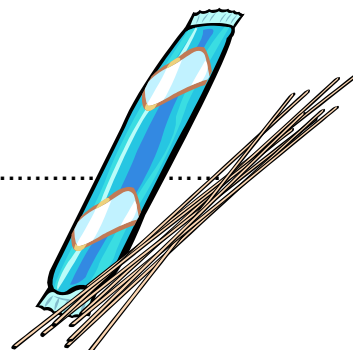

4. What is meant by 'al dente'?

.....

5. What is the name of the piece of equipment used to drain the water from the spaghetti?

.....

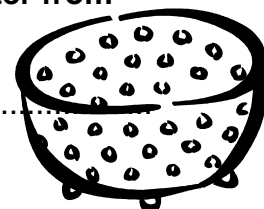

Plenary: Suggest 2 foods you could serve with your spaghetti bolognese:

- a.
- b.

Evaluation.....date.....
...to be completed in full sentences

Comment on the aroma, appearance, taste and texture of your Food product

Aroma.....

Appearance.....

Taste.....

Texture.....

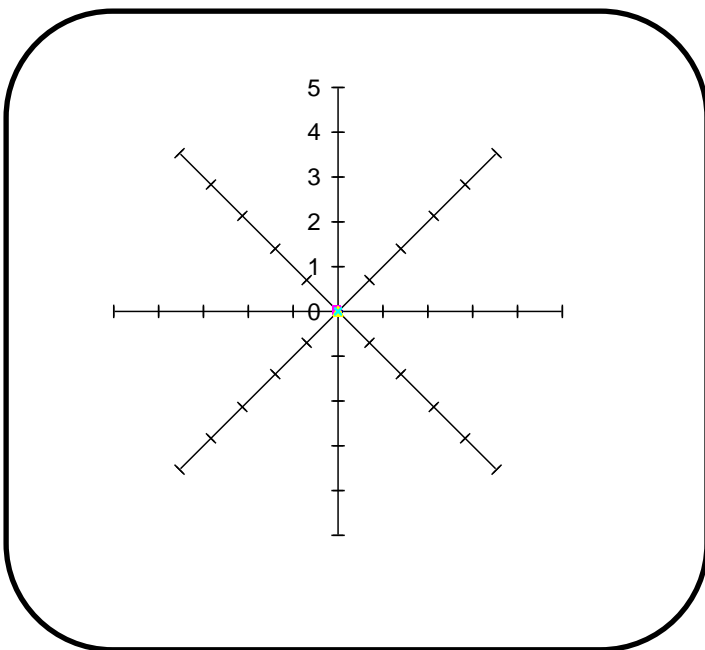

- 5) Use the word bank for sensory descriptive words to complete the star diagram.
- 6) List the skills you have used below:

.....

.....

.....

.....

Which changes/adaptations could you make to improve your dish?

.....

.....

.....

How could you improve your own performance?

.....

.....

.....

Food Science Investigation: Flour

AIM: Determine the suitability of flours in bread making.

Investigate the amount of gluten formed in dough made from different flours

Type of flour	Strong Plain Flour	Self Raising Flour	Cornflour	Gram Flour
Weight in grams before investigation				
Weight in grams after rinsing out the starch				
% of gluten				
Height of gluten ball in mm after being cooked				
Width of gluten ball in mm after being cooked				

Did any of the balls disappear? If so, why do you think this is?

Were any of the samples more might this be?

Bread Research

What happens inside the bread? Fill in the gaps using the words below.

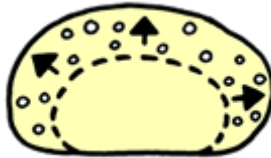
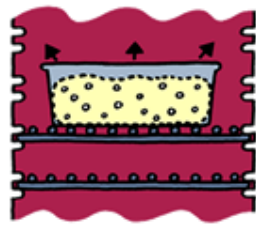
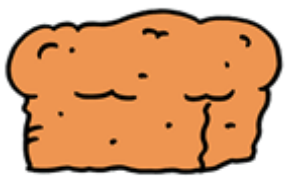
			
<p>The dough is to give the bread its texture. The protein in the flour is stretched to make an elastic dough and pockets of are formed.</p>	<p>Whilst the dough is (resting), bubbles of carbon dioxide gas are formed from the yeast action. These help to stretch the dough and make it rise.</p>	<p>In the oven the gas bubbles (..... and air) expand with the heat. This makes the bread rise further.</p>	<p>Eventually the heat sets the loaf giving it a well risen and a light and spongy texture.</p>

Kneaded



Structure

Gas

Proving

Carbon Dioxide

What yeast needs to work: Fill in the gaps using the words below.

What yeast needs to work	Where it gets it from
Warmth is needed so that yeast cells can grow and multiply water
The yeast needs feeding to grow  which is added to the recipe
The dough needs to become elastic so that it will stretch and rise when the yeast starts to ferment	The action
Time for the yeast to do its work and to produce carbon dioxide gas which raises the dough	The bread is set aside for a period of (about 15 minutes) 
A flour improver may be used to speed it up	Ascorbic Acid (.....)

Vitamin C

Warm

Proving

Sugar

Kneading

Vitamin C

1. What is the chemical name for vitamin C?

.....

2. List four foods which are good sources of vitamin C:



a. c.

b. d.



3. Why do our bodies need vitamin C?

.....

.....

4. Research into why vitamin C is used when making bread:



.....

.....

.....

.....

Bread

Ingredients:

- 200g Strong Plain White Bread F
- 12g Hard Margarine
- ½ Teaspoon Salt
- ½ Teaspoon Sugar
- 7g (1 Sachet) Easy Blend Dried Y
- 120ml Warm Water

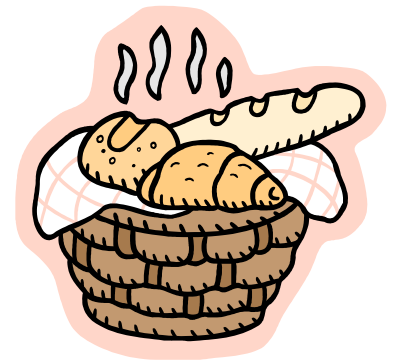

Optional Ingredients:

1 Egg for Glazing

Seaseme Seeds

Poppy Seeds



Equipment:

Weighing Scales, Large Bowl, Flour Dredger, Plastic Spatula, Round Bladed Knife, Measuring Jug, Clean Hands, Baking Tray, Cooling Rack.

Method:

Pre-heat oven to 210°C or gas 7. Grease the baking tray and lightly flour.

Put flour and salt into your bowl. Rub in the margarine.

Crush vitamin C tablet, add to flour and add sugar and yeast, stir together with a spatula.

Measure out the warm water accurately and add it carefully into the bowl. Mix with a round bladed knife. Gather dough together and turn onto a floured table. (Soak bowl so that it is easier to wash up). Knead the dough with your hands for 5-10 minutes to form a soft elastic dough.

Shape and brush with water/egg and sprinkle on topping.

Leave to prove in a warm place for 10-15 minutes.

Bake for 15-20 minutes until golden brown and hollow when the bottom is tapped.

Cool on a wire rack.



Bread Quiz

Starter: List the 7 main ingredients you need to make your bread:

- | | |
|---------|---------|
| 1. | 5. |
| 2. | 6. |
| 3. | 7. |
| 4. | |

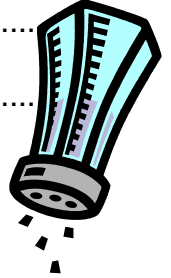

Questions:

1. Why is it important to grease and lightly flour the baking tray?

.....
.....

2. Why is it important to measure out the water carefully?

.....

3. Why do you need to use warm water?

.....

4. What happens to the yeast if you use boiling hot water?

.....

5. Why do we knead bread for approximately 10 minutes?

.....

6. How can you tell that your bread is cooked?

.....

Plenary: Suggest 2 ways for making your bread rolls more interesting:

- a.
- b.

Function of Ingredients

Read the functions below and select the most important ones for your recipe.

Flour

Wheat flour is the most important ingredient in home baking. There are many different types of flour, such as stone ground, wholemeal and cookie flour. Flour as an ingredient has many different and important functions?

- Provides fibre (especially if wholemeal)
- If Self-Raising, makes mixtures rise
- Thickens sauces
- Forms the bulk of bread, pastry and cake mixes
- If wholemeal, provides colour and texture
- Gluten in flour produces a stretchy dough
- Provides carbohydrate, Vitamin B, calcium and iron

Sugar

Ever tasted a sugar-free cookie? Not nice. Some people may even cringe at the thought of having no sugar to dip their strawberries into! Well, although it does it well, making things sweet isn't the only thing that sugars good for. Yes... really!

- Provides sweetness
- If brown, provides colour and texture
- Large amounts prevent micro-organism growth (for example, jam/marmalade)
- Caramelises to produce a brown colour
- Retains moisture
- Helps to trap air in cake mixtures
- Provides carbohydrate

Raising Agents:

Yeast: is a fungus, which needs warmth to develop.

Bicarbonate of soda: this alkali releases its raising agent when combined with acidic ingredients such as yoghurt or milk.

Baking powder: a combination of bicarbonate of soda and cream of tartar. Adding liquid to it causes it to bubble and expand and make cakes rise.

Eggs

From an Egg Mc Muffin, to a lemon meringue pie... You can use them for anything!

- Hold air when beaten
- Coagulate (sets) when heated
- Add colour to mixtures
- Thickens sauces, custards, etc.
- Glaze bread, scones and pastry
- Bind ingredients together
- Provide protein, fat, iron and Vitamins A, B, and E

Fats/Oils

They may not be that good for you, but fats and oils are definitely essential ingredients in many, many dishes.

- Provide flavour
- Keep products moist and extend shelf-life
- Add colour to foods
- Make pastry 'short' by coating the flour to stop gluten developing
- Hold air when creamed with sugar
- Oil forms an emulsion with liquids (for example, mayonnaise)
- Provide energy and Vitamins A and D

Food Packaging

Food Packaging has a number of different **functions**:

- To contain the product
- To protect the food from damage
- To protect the food from contamination
- For convenience
- To identify what the product is
- To provide information
- To extend the shelf life (preserve)
- To make the product easy to handle

There are a number of different **types** of packaging:

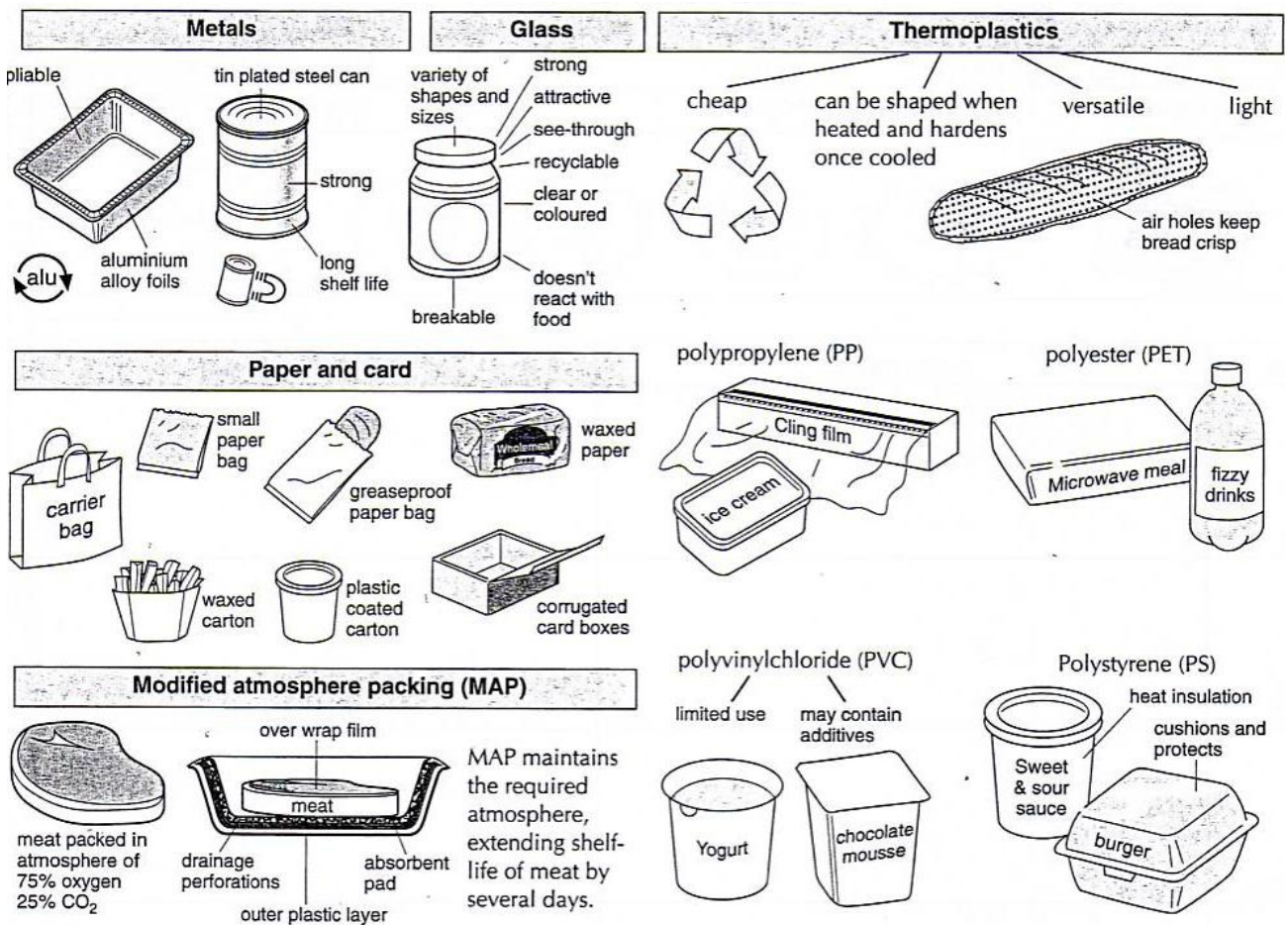

Packaging and Labelling Questions

1. Why is food packaged?

- To the food (help it keep longer)
- To the food from damage.
- To what the product is
- To provide



2. What materials are used to package food?

- Paper
- C.....
- M.....
- G.....
- P.....
- T.....

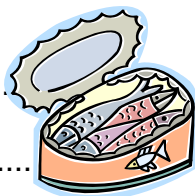

3. What information MUST be on a food label by law?

- N..... of food product.
- Description of the
- List of ing....., listed in order from largest quantity to smallest quantity.
- B..... b..... date.
- Special s..... instructions.
- Manufacturers' n..... and c..... details.
- The process used in m.....
- C..... / heating instructions.
- W..... of the product (not for all foods e.g. bread)



Food Labelling



Labels help me to make choices about the food I buy.

Food labels provide me with lots of important information

The following information is found on food labels by law:

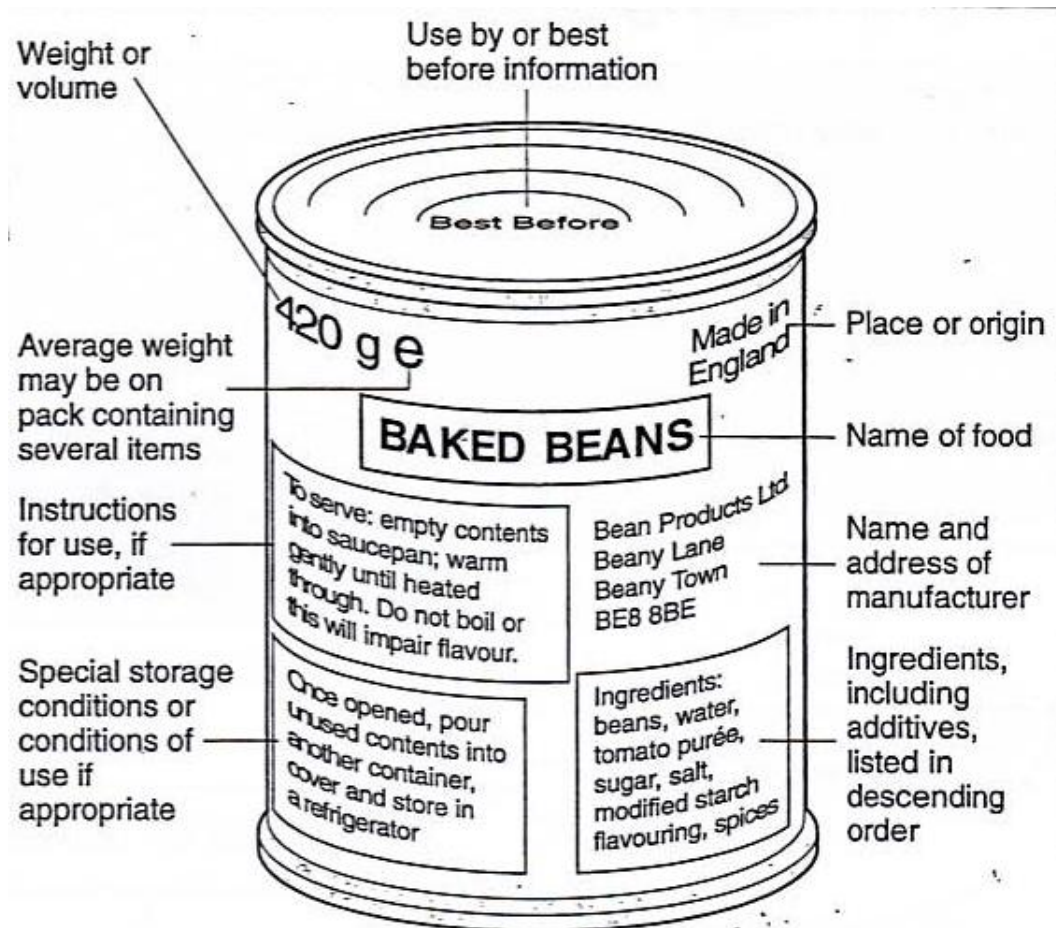

Name the following pieces of equipment and describe what they are used for.



S...e...e

.....
.....



Fi...h S...ic...

.....
.....

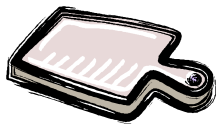

C...o...p...n... Bo...r...

.....
.....



G...a...e...

.....
.....



...ni...e

.....
.....



M...xi...g B.....l

.....
.....



S...u...e...an with l...d

.....
.....



M...a...ur...ng ...u...

.....
.....



Sc...le...

.....
.....



Le...o... S...ue...z...r

.....
.....



Wo...de... S...o...n

.....
.....



Me...su...in... S...o...n...

.....
.....



Ve...e...ab...e P...e...e...

.....
.....



Co...li...g ...a...k

.....
.....



Ba...i...g T...a...

.....
.....



Ro...li...g ...i...

.....
.....

Equipment

Complete the following sentences using the words at the bottom of the page.

1. A and a is used to chop ingredients.
2. Vegetables should be peeled using a, not a chef's knife.
3. To measure 150ml of milk you would use a
4. To measure 150g of flour you would use
5. To stir soup in a saucepan you would use a
6. To grate cheese you would use a
7. To remove lumps from flour and aerate the flour you would use a
8. To cool baked foods such as cakes and muffins you would put the food on a



Missing Words:

Measuring Jug
Sieve
Grater

Knife
Cooling Rack
Chopping Board

Wooden Spoon
Scales
Vegetable Peeler

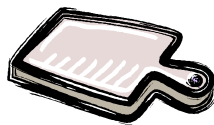

Equipment Word search

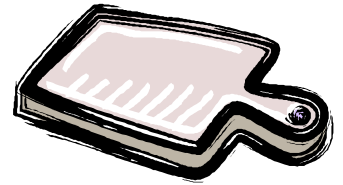

There are the names of twelve pieces of kitchen equipment hidden in the grid below, can you find them?

s	a	u	c	e	p	a	n	d	s
c	k	r	o	f	t	r	a	y	p
t	r	s	l	i	c	s	o	m	o
e	e	k	a	l	w	o	b	o	o
v	t	a	n	r	e	b	e	u	n
e	t	j	d	i	a	h	b	l	a
i	u	u	e	z	f	l	a	d	r
s	c	g	r	a	t	e	r	s	t
n	i	p	g	n	i	l	l	o	r
j	a	b	s	p	e	e	l	e	r

Words:



Rolling pin

Peeler

Spoon

Grater

Fork

Jug

Bowl

Knife

Sieve

Saucepan

Tray

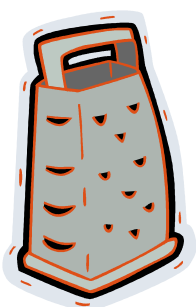

The Gas Cooker

Join up the numbered dots (1-29) to make a picture of a gas cooker. Label the main parts of the cooker by putting these words in the right box.

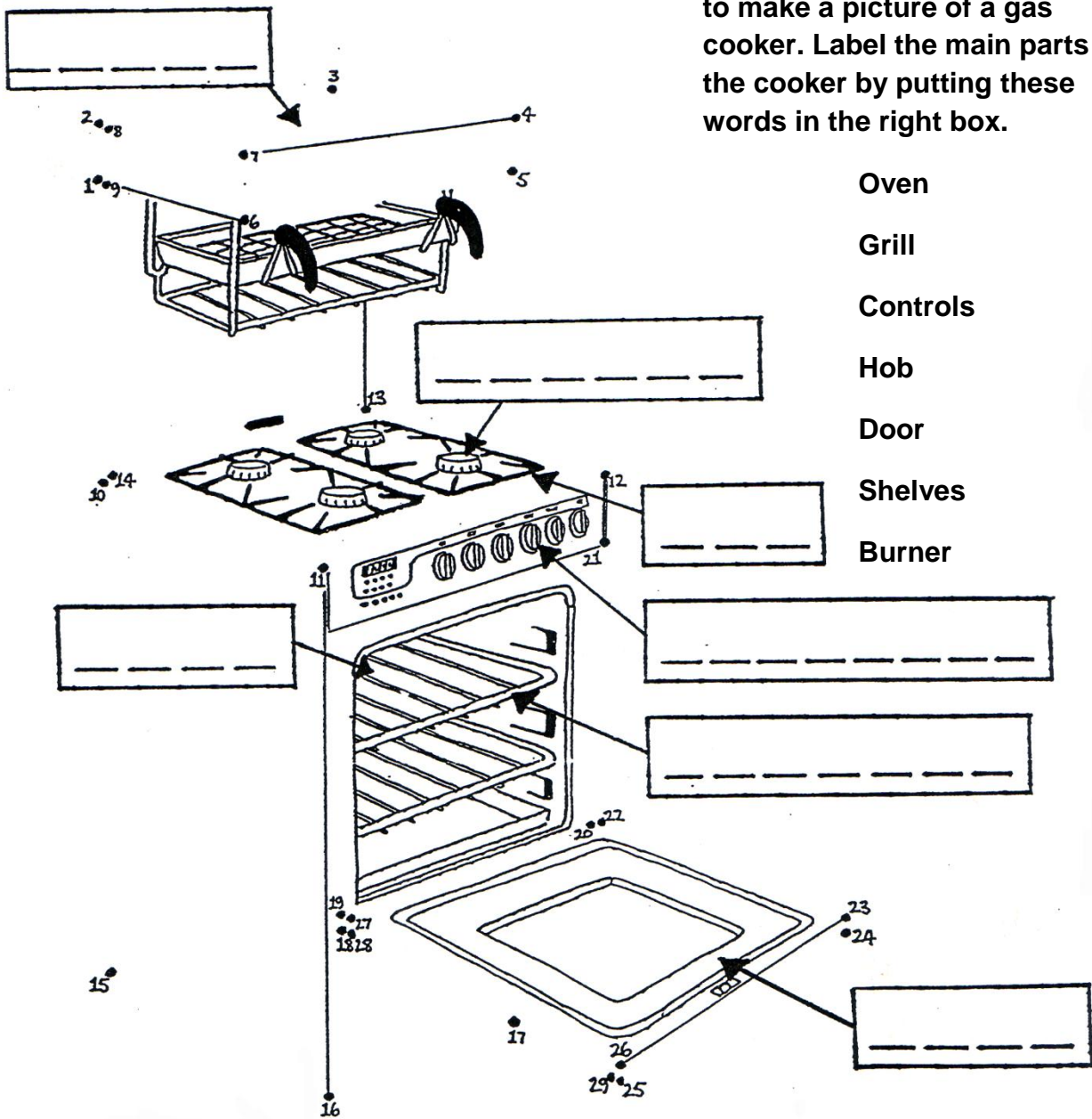

- Oven
- Grill
- Controls
- Hob
- Door
- Shelves
- Burner

Converting Oven Temperatures:

Electric Oven	Gas Oven	Temperature of Oven
140°C	1	Cool
150°C	2	Cool
160°C	3	Moderate
170°C	4	Moderate
180°C	5	Fairly Hot
190°C	6	Fairly Hot
200°C	7	Hot
210°C	8	Hot
220°C	9	Very Hot

